

2025

CATALOG

# ZÉFAL

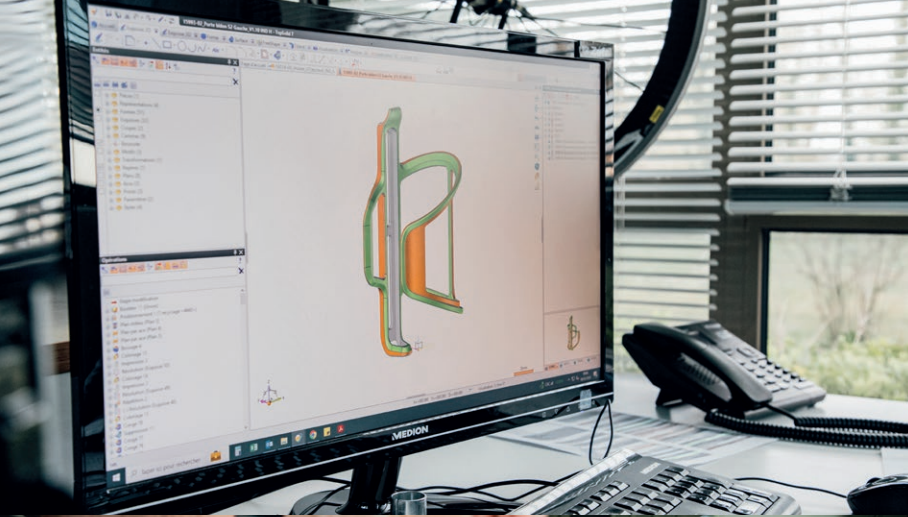



## MADE IN **FRANCE**

Developed and tested by passionate riders, our products are designed and produced largely at our factory in Jargeau, near the city of Orléans. Zéfal has become a real French cultural and industrial heritage which carry on the same philosophy of excellence for several generations.

Thanks to the proximity between the production area and the research department, the design of our products are managed and mastered from start to finish, with attention to detail. For us, this commitment translates to a guarantee of quality and promise to create accessories of excellence with a responsive customer service.

*Zéfal Team*

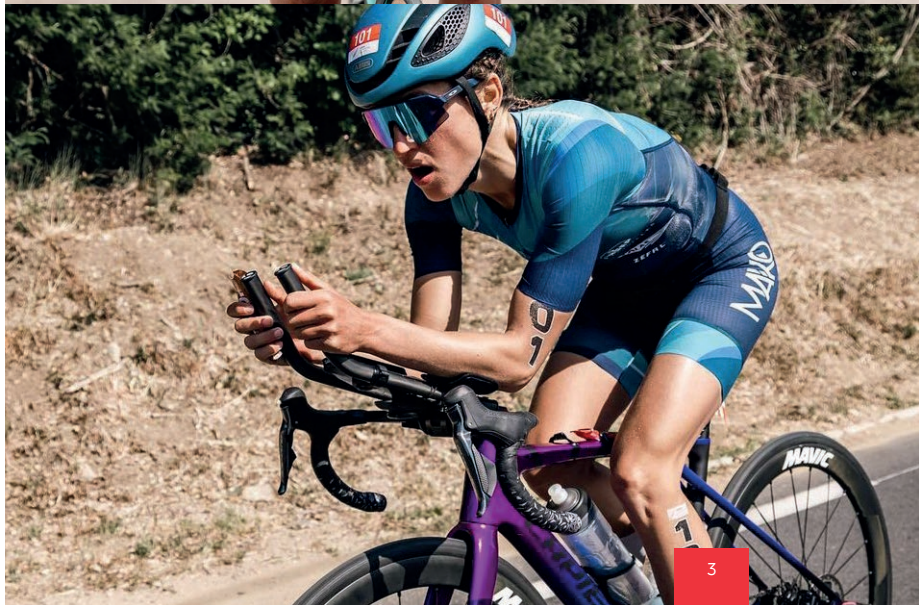
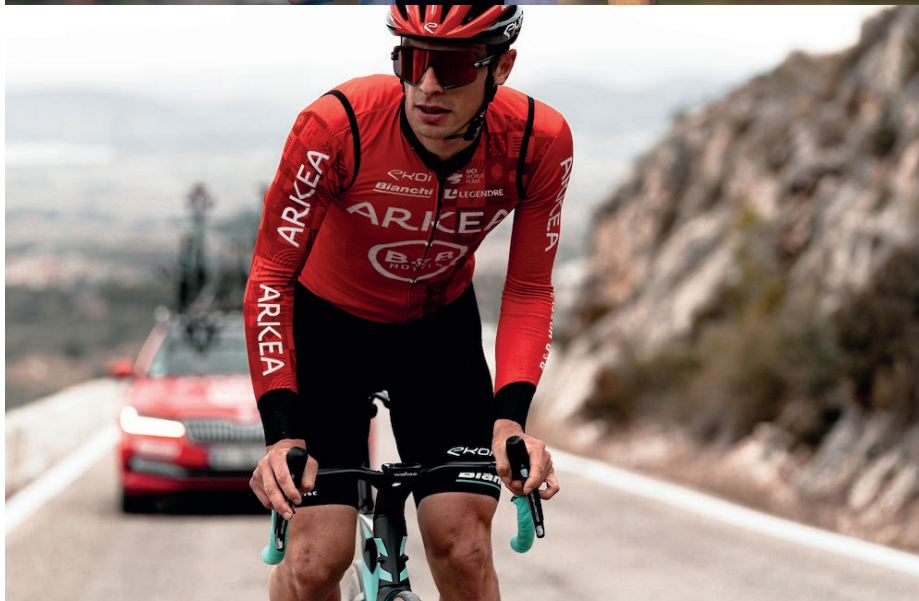

## //

## SPONSORING

Every year Zéfal accompanies and supports a selection of sportsmen and women during their training and competition. The main objective of a partnership for Zéfal is to be able to exchange with demanding sportsmen and mechanics in order to improve the accessories that you will use tomorrow.

By working with Lapierre Mavic Unity on World Cup races, the Poissy Triathlon team, Olympic medallists such as Léonie Périault and Dorian Coninx, and the UCI World Tour teams Arkéa-B&B Hôtels and FDJ-Suez, we can benefit from the best feedback to improve our various products, such as bottle cages, water bottles, lubricants, sealants and much more!

These trusting relationships with our partners are also based on shared values such as a passion for cycling, authenticity and determination to succeed in whatever we do.



# // SUMMARY

**P. 6**

P. 7

P. 13

P. 18

P. 19

**P. 26**

P. 27

P. 34

P. 38

**P. 40**

P. 41

P. 47

P. 49

P. 50

**P. 54**

P. 55

P. 59

P. 64

P. 68

P. 71

P. 73

P. 74

**P. 76**

P. 77

P. 80

P. 82

P. 84

**P. 86**

P. 87

P. 90

P. 93

P. 98

**P. 102****SAFETY**

LIGHTS

MIRRORS

BIKE BELLS

LOCKS

**HYDRATION**

BOTTLE CAGES

BOTTLES

HYDRATION BACKPACKS

**PROTECTION**

MTB MUDGUARDS

ROAD &amp; GRAVEL MUDGUARDS

CITY MUDGUARDS

BIKE PROTECTION

**TRANSPORT**

FRONT BAGS

FRAME BAGS

SADDLE BAGS

BAG FOR RACKS

RACKS

SMARTPHONE HOLDERS

TRANSPORT TOW ROPE

**INFLATION**

MINI-PUMPS

CO2 PUMPS

PUMPS

FLOOR PUMPS

**MAINTAIN**

CLEANERS

LUBRICANTS

REPAIR

PREVENT

**MISCELLANEOUS**



**// SAFETY**



//

« **DON'T JUST RIDE,  
GET NOTICED.** »

Zéfal returns to the lighting market with top-of-the-range, durable products to complete its global range of accessories for cyclists.

**Autonomy, reliability and performance** were the main components of our specifications when designing this new lighting range.

Rechargeable, adaptable to several types of supports, and waterproof to IPX6 standards, this range of 8 products sets Zéfal firmly on a new standard of quality, in line with our recent launches.

Because the **safety of the cyclist** on his playground should never be an obstacle to his practice, we have designed a **light and robust range**, for all types of use.

**Stop being viewed.  
Be supervised !**

# SUPERVISION F1500

Ref. 1015

## // 1500 LUMEN RECHARGEABLE FRONT LIGHT

NEW

The Supervision F1500 is a front light for bicycles with a very high luminosity of up to 1500 lumens.

It has been designed for demanding cyclists looking for reliability and performance. With its dual lens and wider field of vision, this light makes it possible to light the way in an unlit night-time environment. It is particularly suitable for mountain bikers and cyclists on night rides.

The Supervision F1500 is IPX6 certified, making it water and impact resistant. Its machined aluminium casing has been designed to cool more quickly. It can be mounted on either our adjustable bracket or the camera mount.

Its central button makes it easy to use, with quick access to the various setting modes, but the remote control supplied also lets you control your lighting without taking your hands off the handlebars.

Mode and battery indicators keep you informed at all times of the current mode and remaining battery life. This light has 5 operating modes: 3 steady and 2 flashing modes.



**GREAT AUTONOMY** - Up to 65 hours of operation depending on the chosen mode.

**EASY ADJUSTMENT** - Central button for easy access and remote control.

**UNIVERSAL MOUNTING** - Removable bracket for handlebar or camera mount.

**WATERPROOF** - IPX6 certified.

**RECHARGEABLE** - Recharges via USB-C port (cable not supplied).



### > MATERIAL

Aluminium and plastic

### > TYPE OF LIGHTING

LED

### > BATTERY TYPE

Polymer

### > BATTERY CAPACITY

3.7 V 5000 mAh

### > MODES/FIXED RUNTIME

1500 lm (1hrs40) / 800 lm (3hrs15) / 100 lm (19hrs)

### > MODES/FLASH DURATION

500 lm (18hrs) / 200 lm (65hrs)

### > WATERPROOFING IPX6

### > RECHARGING

Via USB-C port (cable not supplied)

### > RECHARGE TIME 2 hrs (5V 2A)

### > ATTACHMENT

Removable handlebar mount

### > DIMENSIONS

105 x 51 x 35 mm

### > WEIGHT

232 g



## SUPERVISION F800

Ref. 1016

NEW

### // 800 LUMEN RECHARGEABLE FRONT LIGHT



**GREAT AUTONOMY** - Up to 35 hours of operation depending on the mode chosen.

**EASY ADJUSTMENT** - Central button for easy access.

**UNIVERSAL MOUNTING** - Removable bracket for handlebar.

**WATERPROOF** - IPX6 certified.

**RECHARGEABLE** - Recharges via USB-C port (cable not supplied).



## SUPERVISION F200

Ref. 1017

NEW

### // 200 LUMEN RECHARGEABLE FRONT LIGHT



**GREAT AUTONOMY** - Up to 86 hours of operation depending on the mode chosen.

**EASY ADJUSTMENT** - Central button for easy access.

**UNIVERSAL MOUNTING** - Removable bracket for handlebar.

**WATERPROOF** - IPX6 certified.

**RECHARGEABLE** - Recharges via USB-C port (cable not supplied).



#### SUPERVISION F800

- > **MATERIAL** Plastic and aluminium
- > **TYPE OF LIGHTING** LED
- > **BATTERY TYPE** Polymer
- > **BATTERY CAPACITY** 3.7 V 1500 mAh
- > **MODES/FIXED RUNTIME**  
800 lm (1hrs30) / 200 lm (4hrs) / 50 lm (16hrs)
- > **MODES/FLASH DURATION**  
500 lm (11hrs) / 200 lm (35hrs)
- > **WATERPROOFING** IPX6
- > **RECHARGING**  
Via USB-C port (cable not supplied)
- > **RECHARGE TIME** 3 hrs (5V 1A)
- > **ATTACHMENT**  
Removable handlebar mount
- > **DIMENSIONS**  
105 x 41 x 35 mm
- > **WEIGHT**  
167 g

#### SUPERVISION F200

- > **MATERIAL** Plastic
- > **TYPE OF LIGHTING** LED
- > **BATTERY TYPE** Polymer
- > **BATTERY CAPACITY** 3.7 V 1500 mAh
- > **MODES/FIXED RUNTIME**  
200 lm (2hrs) / 100 lm (4hrs15)
- > **MODES/FLASH DURATION**  
200 lm (18hrs) / 50 lm (86hrs)
- > **WATERPROOFING** IPX6
- > **RECHARGING**  
Via USB-C port (cable not supplied)
- > **RECHARGE TIME** 2 hrs (5V 1A)
- > **ATTACHMENT**  
Removable hanger attachment
- > **DIMENSIONS**  
105 x 41 x 35 mm
- > **WEIGHT**  
137 g

# SUPERVISION R150

Ref. 1012

NEW

## // 150 LUMEN RECHARGEABLE REAR LIGHT

The Supervision R150 is a rear light for bicycles with a maximum light output of 150 lumens. Very powerful and with a very wide angle of vision, this light ensures optimum visibility for cyclists on the road, both at night and during the day. It's ideal for ultra-cycling enthusiasts looking for a reliable, high-performance rear light, thanks to its long battery life and high luminous intensity.

With its silicone strap and interchangeable clip, it can be fitted without tools to any part of the frame or on a bag. Its central button makes it easy to use, with quick access to the different setting modes. This light has 5 operating modes: 3 steady and 2 flashing modes.

IPX6 certified, the Supervision R150 is water-resistant, so it can continue to be used in rainy conditions. Its long battery life means you'll always be seen on your route.

Available in Supervision F200/R150 #1000 set.



**GREAT AUTONOMY** - Up to 16h of operation depending on the mode chosen.

**EASY ADJUSTMENT** - Central button for easy access.

**UNIVERSAL MOUNTING** - Silicone strap to mount on the frame or clip to mount on a bag.

**WATERPROOF** - IPX6 certification.

**RECHARGEABLE** - Recharging via USB-C port (cable not supplied).



### > MATERIAL

Plastic

### > TYPE OF LIGHTING

LED

### > BATTERY TYPE

Polymer

### > BATTERY CAPACITY

3.7 V 1200mAh

### > MODES/FIXED RUNTIME

80lm (3hrs) / 50lm (5hrs30) / 15lm (16hrs)

### > MODES/FLASH DURATION

150lm (8hrs) / 50lm (16hrs)

### > WATERPROOFING IPX6

### > RECHARGING

Via USB-C port (cable not supplied)

### > RECHARGE TIME 2hrs (5V 0,6A)

### > ATTACHMENT

Silicone strap or clip

### > DIMENSIONS

78 x 47 x 28 mm

### > WEIGHT

70 g

## VISION F20

Ref. 1011

### // 20 LUMEN RECHARGEABLE FRONT LIGHT



**GREAT AUTONOMY** - Up to 90 hours of operation depending on the mode selected.

**EASY TO ADJUST** - Central button for easy access.

**COMPACT** - Compact size.

**WATERPROOF** - IPX6 certification.

**RECHARGEABLE** - Recharging via USB-C port (cable not supplied).



NEW

## VISION R20

Ref. 1013

### // 20 LUMEN RECHARGEABLE REAR LIGHT



**GREAT AUTONOMY** - Up to 33 hours of operation depending on the mode chosen.

**EASY TO ADJUST** - Central button for easy access.

**COMPACT** - Compact size.

**WATERPROOF** - IPX6 certification.

**RECHARGEABLE** - Recharging via USB-C port (cable not supplied).



NEW



#### VISION F20

- > **MATERIAL** Plastic
- > **TYPE OF LIGHTING** White COB
- > **BATTERY TYPE** Polymer
- > **BATTERY CAPACITY** 3.7 V 200mAh
- > **MODES/FIXED RUNTIME**  
20lm (3hrs30) / 5lm (14hrs)
- > **MODES/FLASH DURATION**  
20lm (25hrs) / 5lm (65hrs)
- > **WATERPROOFING** IPX6
- > **RECHARGING**  
Via USB-C port (cable not supplied)
- > **RECHARGE TIME** 2hrs (5V 0,1A)
- > **ATTACHMENT**  
2 o-rings (1x Ø30mm + 1x Ø40mm)
- > **DIMENSIONS**  
52 x 28 x 20 mm
- > **WEIGHT**  
20 g

#### VISION R20

- > **MATERIAL** Plastic
- > **TYPE OF LIGHTING** Red COB
- > **BATTERY TYPE** Polymer
- > **BATTERY CAPACITY** 3.7 V 200mAh
- > **MODES/FIXED RUNTIME**  
20lm (2hrs) / 5lm (8hrs)
- > **MODES/FLASH DURATION**  
20lm (9hrs) / 5lm (33hrs)
- > **WATERPROOFING** IPX6
- > **RECHARGING**  
Via USB-C port (cable not supplied)
- > **RECHARGE TIME** 2hrs (5V 0,1A)
- > **ATTACHMENT**  
2 o-rings (1x Ø30mm + 1x Ø40mm)
- > **DIMENSIONS**  
52 x 28 x 20 mm
- > **WEIGHT**  
20 g

## SUPERVISION F200 R150 SET

Ref. 1000

// SET OF 200 LUMEN FRONT AND 150 LUMEN REAR LIGHTS



## VISION F20 R20 SET

Ref. 1001

// SET OF 20 LUMEN FRONT AND REAR LIGHTS



## LIGHT HANDLEBAR MOUNT

Ref. 1005

// BIKE LIGHT BRACKET FOR HANDLEBARS

- + **STABLE** - The silicone strap prevents the support from slipping on the handlebar.
- + **UNIVERSAL** - Fits most handlebars.



## HELMET BRACKET

Ref. 1006

// BIKE LIGHT BRACKET FOR HELMET

- + **GO PRO COMPATIBLE** - Mounts a ZEFAL light or mini camera.



## LIGHT REMOTE BUTTON

Ref. 1007

// REMOTE CONTROL FOR BICYCLE FRONT LIGHTING



### LIGHT HANDLEBAR MOUNT

- > **MATERIAL** Plastic + silicone
- > **STRAP LENGTH** 100 mm
- > **DIMENSIONS** 65 x 24 x 55 mm
- > **WEIGHT** 26 g
- > **INSTALLATION** Ø22- 38 mm

### HELMET BRACKET

- > **MATERIAL** Plastic
- > **STRAP LENGTH** 380 mm + extension 250 mm
- > **DIMENSIONS** 60 x 50 x 40 mm
- > **WEIGHT** 90 g

### LIGHT REMOTE BUTTON

- > **MATERIAL** Plastic and aluminium
- > **VELCRO STRAP LENGTH** 80 mm
- > **CABLE LENGTH** 540 mm
- > **DIMENSIONS** 25 x 30 x 15 mm
- > **WEIGHT** 9 g

# ESPION E100 CARGO

Ref. 4772

## // HANDLEBAR-MOUNTED MIRROR FOR LONGTAIL AND CARGO BIKES

The Espion E100 Cargo is a wide-angle, handlebar-mounted mirror specifically for Longtail and Cargo bikes. With an extra-large main mirror and a vibration-free stem, this mirror makes it easy to anticipate potential hazards coming from behind. The small additional mirror provides a clear view of the rear of the bike.

On a Longtail or Cargo bike, this means you can keep an eye on your children or any other cargo entering the blind spot of the main mirror's field of vision.

The mirrors are mounted on ball-and-socket joints for optimum, constant adjustment over time, while the pivoting arm optimises positioning. The Espion E100 Cargo is mounted on the left-hand side of the handlebars.



**NO BLIND SPOTS** - Excellent visibility thanks to its double mirror.

**EBIKE FRIENDLY** - On handlebars  $\varnothing$  22 mm to  $\varnothing$  25.4 mm.

**STABLE AND RIGID MOUNTING** - The vision remains clear on tarmac roads. Long-lasting adjustment.

**DURABILITY** - Unbreakable chrome-plated ABS mirror. Arm swivels in the event of a fall.

**PARKING MODE** - Mirror can be folded down and repositioned without adjustment.



- > **MATERIAL** Chrome plated ABS
- > **MIRROR** Convex
- > **ORIENTATION** Adjustable on mounting axis and 3D adjustable - Parking mode
- > **SIZE OF THE MIRROR** 80 cm<sup>2</sup>
- > **MOUNTING** on handlebars  $\varnothing$  22 mm to  $\varnothing$  25.4 mm
- > **DIMENSIONS** 280 x 210 x 80 mm
- > **WEIGHT** 169 g

**ESPION E80**

Ref. 4790 - 4791

**// HANDLEBAR-MOUNTED MIRROR FOR E-BIKE****EXTRA-LARGE MIRROR** - Very high visibility.**EBIKE FRIENDLY** - On handlebars Ø 22 mm to Ø 25.4 mm.**STABLE AND RIGID MOUNTING** - The vision remains clear on tarmac roads. Long-lasting adjustment.**DURABILITY** - Unbreakable chrome-plated ABS mirror. Arm swivels in the event of a fall.**PARKING MODE** - Mirror can be folded down and repositioned without adjustment.**ESPION Z56**

Ref. 4760L - 4760R

**// HANDLEBAR-MOUNTED MIRROR FOR BIKE****E-BIKE FRIENDLY** - Compatible electric bike.**LARGE MIRROR** - Great visibility.**SOLID MIRROR** - The mirrors are made of unbreakable ABS chrome and therefore are not dangerous in the event of a fall.**ADJUSTABLE** - Easy to adjust, stable.**FOLDABLE** - For storage and protection of the mirror.

## ESPION E80

- > **MATERIAL** Chrome plated ABS
- > **MIRROR** Convex
- > **ORIENTATION** Adjustable on mounting axis and 3D adjustable - Parking mode
- > **SIZE OF THE MIRROR** 80 cm<sup>2</sup>
- > **MOUNTING** On handlebars Ø 22 mm to Ø 25.4 mm
- > **DIMENSIONS** 240 x 210 x 80 mm
- > **WEIGHT** 143 g

## ESPION Z56

- > **MATERIAL** Chrome plated ABS
- > **MIRROR** Convex
- > **ORIENTATION** Adjustable on mounting axis and 3D adjustable
- > **SIZE OF THE MIRROR** 56 cm<sup>2</sup>
- > **MOUNTING** On handlebar Ø 22 mm (left or right depending on version)
- > **DIMENSIONS** 220 x 235 x 42 mm
- > **WEIGHT** 75 g

## ZL TOWER 80

Ref. 4746

### // MIRROR FOR E-BIKE HANDLEBAR END ON ARTICULATED ARM



**EXTRA-LARGE MIRROR** - Very high visibility.

**STABLE AND RIGID MOUNTING** - Good rigidity thanks to the glass fibre reinforced polyamide material. The mirror remains stable and does not move while riding.

**SOLID MIRROR** - The mirrors are made of unbreakable ABS chrome and therefore have no risk of breaking in the event of fall.

**REVERSIBLE** - Can be attached to either side of the handlebar.



## ZL TOWER 56

Ref. 4744

### // MIRROR FOR HANDLEBAR END ON ARTICULATED ARM



**EBIKE COMPATIBLE** - Ideal for electric bikes.

**STABLE AND RIGID MOUNTING** - Good rigidity thanks to the glass fibre reinforced polyamide material. The mirror remains stable and does not move while riding.

**SOLID MIRROR** - The mirrors are made of unbreakable ABS chrome and therefore have no risk of breaking in the event of fall.

**REVERSIBLE** - Can be attached to either side of the handlebar.

**LARGE MIRROR** - High visibility.



## DOOBACK II

Ref. 4770L - 4770R

### // BIKE MIRROR FOR STRAIGHT AND STRAIGHT CURVED HANDLEBAR ENDS



**EBIKE COMPATIBLE** - Ideal for electric bikes.

**LARGE MIRROR** - High Visibility.

**8 ADJUSTMENT NOTCHES** - Ideal for straight and straight curved handlebars.

**SOLID MIRROR** - The mirrors are made of unbreakable ABS chrome and therefore have no risk of breaking in the event of fall.

**FOLDABLE** - For storage and protection of the mirror.



#### ZL TOWER 80

- > **MATERIAL** Chrome plated ABS
- > **MIRROR** Convex
- > **ORIENTATION** Adjustable on mounting axis and 3D adjustable
- > **SIZE OF THE MIRROR** 80 cm<sup>2</sup>
- > **MOUNTING**  
On handlebars Ø 22 mm or bar end fitting (Ø 16 mm - Ø 22 mm)
- > **DIMENSIONS**  
115 x 185 x 90 mm
- > **WEIGHT** 103 g

#### ZL TOWER 56

- > **MATERIAL** Chrome plated ABS
- > **MIRROR** Convex
- > **ORIENTATION** Adjustable on mounting axis and 3D adjustable
- > **SIZE OF THE MIRROR** 56 cm<sup>2</sup>
- > **MOUNTING**  
on handlebars Ø 22 mm or bar end fitting (Ø 16 mm - Ø 22 mm)
- > **DIMENSIONS**  
97 x 180 x 90 mm
- > **WEIGHT** 82 g

#### DOOBACK II

- > **MATERIAL** Chrome plated ABS
- > **MIRROR** Convex
- > **ORIENTATION** Adjustable on mounting axis and 3D adjustable
- > **SIZE OF THE MIRROR** 56 cm<sup>2</sup>
- > **MOUNTING** Bar end fitting (left or right depending on version) 16 mm - 22 mm
- > **DIMENSIONS**  
112 x 120 x 23 mm
- > **WEIGHT** 76 g

**CYCLOP**

Ref. 4710

**// UNIVERSAL BIKE MIRROR FOR HANDLEBAR ENDS**

- REVERSIBLE** - Can be attached to either side of the handlebar.
- SOLID MIRROR** - The mirrors are made of unbreakable ABS chrome and therefore have no risk of breaking in the event of fall.
- TRIPLE ADJUSTMENT** - Orientation tailored to your position.
- FOLDING UNDER THE HANDLEBAR** - Storage and protection of the mirror.

**SPIN 25**

Ref. 4742

**// MIRROR FOR ROAD BIKE HANDLEBAR ENDS**

- SPORT USE ON ROAD BIKES** - Discret, lightweight and suitable for curved handlebars.
- REVERSIBLE** - Can be attached to either side of the handlebar.
- SOLID MIRROR** - The mirrors are made of unbreakable ABS chrome and therefore have no risk of breaking in the event of fall.
- TRIPLE ADJUSTMENT** - Orientation tailored to your position.
- FOLDABLE - CAN BE TUCKED AWAY UNDER THE HANDLEBAR** - Storage and protection of the mirror.

**SPIN 15**

Ref. 4740

**// MIRROR FOR ROAD BIKE HANDLEBAR ENDS**

- SPORT USE ON ROAD BIKES** - Discret, lightweight and suitable for curved handlebars.
- REVERSIBLE** - Can be attached to either side of the handlebar.
- SOLID MIRROR** - The mirrors are made of unbreakable ABS chrome and therefore have no risk of breaking in the event of fall.
- TRIPLE ADJUSTMENT** - Orientation tailored to your position.
- FOLDABLE - CAN BE TUCKED AWAY UNDER THE HANDLEBAR** - Storage and protection of the mirror.



CYCLOP

SPIN 25

SPIN 15

- > **MATERIAL** Chrome plated ABS
- > **MIRROR** Convex
- > **ORIENTATION** Adjustable on 3 axes
- > **SIZE OF THE MIRROR** 46 cm<sup>2</sup>
- > **MOUNTING**  
Universal bar end fitting (left and right) 16 mm - 22 mm
- > **DIMENSIONS**  
65 x 165 x 25 mm
- > **WEIGHT** 60 g

- > **MATERIAL** Chrome plated ABS
- > **MIRROR** Convex
- > **ORIENTATION** Adjustable on 3 axes
- > **SIZE OF THE MIRROR** 25 cm<sup>2</sup>
- > **MOUNTING**  
Universal bar end fitting (left and right) 16 mm - 22 mm
- > **DIMENSIONS**  
60 x 125 x 22 mm
- > **WEIGHT** 57 g

- > **MATERIAL** Chrome plated ABS
- > **MIRROR** Convex
- > **ORIENTATION** Adjustable on 3 axes
- > **SIZE OF THE MIRROR** 15 cm<sup>2</sup>
- > **MOUNTING**  
Universal bar end fitting (left and right) 16 mm - 22 mm
- > **DIMENSIONS**  
25 x 110 x 22 mm
- > **WEIGHT** 45 g



## SPY 15 Ref. 4715

### // MULTI-POSITION MINI BIKE MIRROR



**E-BIKE FRIENDLY** - Universal clip-on mirror - diameter 22 mm to 86 mm.

**SOLID MIRROR** - The mirrors are made of unbreakable ABS chrome and therefore are not dangerous in the event of a fall.

**CAN BE MOUNTED IN SEVERAL LOCATIONS** - Adapts to your position on the bike, on the right or the left.

**DOUBLE ADJUSTMENT** - Orientation tailored to your position.



## Z EYE Ref. 4730

### // HELMET MIRROR FOR CYCLISTS



**REVERSIBLE** - Can be attached to either side of the helmet.

**SOLID MIRROR** - The mirrors are made of unbreakable ABS chrome and therefore are not dangerous in the event of a fall.

**UNIVERSAL MOUNTING** - Compatible with all helmets.

**DOUBLE ADJUSTMENT AT 360°** - Orientation tailored to your position.

**QUICK MOUNTING** - Easy and quick installation.



#### SPY 15

- > **MATERIAL** Chrome plated ABS
- > **MIRROR** Convex
- > **ORIENTATION** Multiple rotating and longitudinal adjustments
- > **SIZE OF THE MIRROR** 15 cm<sup>2</sup>
- > **MOUNTING**  
Snap-on mounting with rubber strap  
22mm - 86 mm
- > **DIMENSIONS**  
55 x 85 x 35 mm
- > **WEIGHT** 28 g

#### Z EYE

- > **MATERIAL** Chrome plated ABS
- > **MIRROR** Convex
- > **ORIENTATION** Multiple rotating and longitudinal adjustments
- > **SIZE OF THE MIRROR** 9 cm<sup>2</sup>
- > **MOUNTING**  
Universal with Velcro® straps
- > **DIMENSIONS**  
70 x 283 x 45 mm
- > **WEIGHT** 22 g

## DOOWAH

Ref. 1021 - 1022

### // PANT-TIES

- +** **QUICK MOUNTING** - Easy and quick installation.
- 2 IN 1** - Pant-tie and reflective strip.
- RESISTANT MATERIAL** - Optimum security.



## PIING

Ref. 1060A - 1060B

### // BIKE BELL

- +** **FAST INSTALLATION** - Easy without tools.
- UNIVERSAL MOUNTING** - Fits all handlebars on diameter 19 to 27 mm.
- POWERFUL SOUND** - Loud, clear and nice.



## CLASSIC BIKE BELL

Ref. 1062 - 1063

### // BIKE BELL

- +** **SIMPLE AND STYLISH** - Vintage design.
- POWERFUL SOUND** - Loud, clear and nice.
- EASY TO USE** - Easy to use spring hammer.
- UNIVERSAL MOUNTING** - Fits all handlebars on diameter 22 to 25.4 mm.
- FAST INSTALLATION** - Easy without tools.



#### DOOWAH

- > **MATERIAL** Nylon
- > **FIXATION**  
To roll with a Velcro®
- > **COLORS**  
Black (#1021)  
Fluorescent yellow (#1022)
- > **DIMENSIONS**  
25 x 380 mm
- > **WEIGHT** 2 x 6 g

#### PIING

- > **MATERIAL** Aluminium cap - Technopolymer fixation
- > **FIXATION** Clip on handlebar from Ø 19 to 27 mm
- > **COLORS**  
Black (#1060A) - Silver (#1060B)
- > **DIMENSIONS**  
60 x 38 x 65 mm
- > **WEIGHT** 21 g

#### CLASSIC BIKE BELL

- > **MATERIAL** Brass bell - Technopolymer support
- > **FIXATION**  
screwed without tools on Ø22 to 25.4mm
- > **COLORS**  
Gold (#1062) - Black (#1063)
- > **DIMENSIONS**  
65 x 35 x 55 mm
- > **WEIGHT** 54 g

## K-TRAZ U20

Ref. 4930

### // HIGH-SECURITY U-LOCK



**MAXIMUM SAFETY** - Security Level 20 - For areas with a high risk of theft.

**CERTIFICATION** - Classe SRA.

**KEYLOSS SERVICE** - Reproduction of keys in case of loss. Unique serial number.

**COATING** - Optimal protection of your frame's paintwork.

CLASSE  
SRA

## K-TRAZ U20S

Ref. 4931

### // HIGH-SECURITY U-LOCK



**MAXIMUM SAFETY** - Security Level 20 - For areas with a high risk of theft.

**CERTIFICATION** - Classe SRA.

**KEYLOSS SERVICE** - Reproduction of keys in case of loss. Unique serial number.

**COATING** - Optimal protection of your frame's paintwork.

**COMPACT** - Less weight and reduced size.

CLASSE  
SRA

## K-TRAZ HOLSTER

Ref. 4905

### // UNIVERSAL BRACKET FOR U-LOCK



**UNIVERSAL** - Adjustable system allows all sizes of U-lock to be fitted.

**PROTECTIVE** - Silicone-coated strap protects frame from scratches and abrasion.

**EASY TO INSTALL** - Quick and easy to mount and remove.

**ROBUST** - Supports weights up to 4kg.



NEW



#### K-TRAZ U20

- > **TYPE** U-lock
- > **SECURITY LEVEL** 20
- > **MATERIAL** Hardened steel
- > **SECTION** Ø 18 mm
- > **KEY / CODE** Keys (3 included)
- > **DIMENSIONS** 185 x 305 x 48 mm
- > **WEIGHT** 2.550 kg

#### K-TRAZ U20S

- > **TYPE** U-lock
- > **SECURITY LEVEL** 20
- > **MATERIAL** Hardened steel
- > **SECTION** Ø 18 mm
- > **KEY / CODE** Keys (3 included)
- > **DIMENSIONS** 185 x 210 x 48 mm
- > **WEIGHT** 2.150 kg

#### K-TRAZ HOLSTER

- > **TYPE** Universal bracket for U-Lock
- > **MATERIAL** Polyamide + Silicone
- > **COMPATIBILITY** For U-locks between 120 mm and 230 mm wide
- > **MOUNTING** Velcro
- > **MAXIMUM LOAD** Up to 4 kg
- > **DIMENSIONS** 180 x 100 x 80 mm
- > **WEIGHT** 56 g

## K-TRAZ U17

### // U-LOCK

- +** **HIGH SECURITY** - Security level 17 - For areas with a high risk of theft.
- Z SAFE +** - Highly powerful quadruple locking system. Delivers a very high degree of protection in risky places.
- HIGH RESISTANCE** - Tensile and torsion strength. Antitheft and anti drilling.
- LOSS OF KEY SERVICE** - Duplication of keys in case of loss. Unique serial number.
- CERTIFICATION** - FUB - 2 roues / Sold Secure Gold.



Ref. 4947A

Ref. 4947B



### + K-TRAZ U17 CABLE

U-LOCK WITH CABLE

## K-TRAZ U13 CABLE CODE

Ref. 4944C

### // U-LOCK WITH CODE AND CABLE

- +** **GOOD SECURITY** - Security level 13 - For areas with a moderate risk of theft.
- Z SAFE BALL** - Adjustable code locking system. High protection against robbery.
- 4 DIGIT COMBINATION SYSTEM** - 10000 possible combinations.
- HIGH RESISTANCE** - Tensile and torsion strength. Antitheft and anti drilling.



## K-TRAZ U13 CABLE

Ref. 4944B

### // U-LOCK WITH CABLE

- +** **Z SAFE** - Powerful double locking system. High resistance against impacts and twists.
- LOSS OF KEY SERVICE** - Duplication of keys in case of loss. Unique serial number.
- CERTIFICATION** - FUB - 2 roues / Sold Secure Silver.



K-TRAZ U17

K-TRAZ U17 CABLE

K-TRAZ U13 CABLE CODE

K-TRAZ U13 CABLE

- > **TYPE** U-lock
- > **SECURITY LEVEL** 17
- > **MATERIAL** Hardened steel
- > **MOUNTING** Ø 14 mm
- > **FIXATION** Adjustable on down tube - Ø from 20 to 42 mm
- > **KEYS (3 INCLUDED)**
- > **DIMENSIONS** 172 x 290 x 40 mm
- > **WEIGHT** 1.47 kg

- > **TYPE** U-lock
- > **SECURITY LEVEL** 17
- > **MATERIAL** Hardened steel
- > **SECTION** Ø 14 mm (U) Ø 10 mm (cable)
- > **MOUNTING** Adjustable on down tube - Ø from 20 to 42 mm
- > **KEYS (3 INCLUDED)**
- > **DIMENSIONS** 172 x 290 x 40 mm
- > **WEIGHT** 1.47 kg + 0,300 kg

- > **TYPE TYPE** U-lock with code and cable
- > **SECURITY LEVEL** 13
- > **MATERIAL** Hardened steel. Flexible twisted steel wire with a tough vinyl cable cover.
- > **SECTION** Ø 13 mm (U) Ø 10 mm (cable)
- > **MOUNTING** Adjustable on down tube - Ø from 20 to 42 mm
- > **CODE**
- > **DIMENSIONS** 190 x 310 x 60 mm
- > **WEIGHT** 1.15 kg

- > **TYPE** U-lock
- > **SECURITY LEVEL** 13
- > **MATERIAL** Hardened steel.
- > **SECTION** Ø 13 mm (U) Ø 10 mm (cable)
- > **MOUNTING** Adjustable on down tube - Ø from 20 to 42 mm
- > **KEYS (3 INCLUDED)**
- > **DIMENSIONS** 1178 x 310 x 60 mm
- > **WEIGHT** 1.4 kg

## K-TRAZ U13 Ref. 4944A

### // U-LOCK



- GOOD SECURITY** - Security level 13 - For areas with a moderate risk of theft.
- Z SAFE** - Powerful double locking system. High resistance against impacts and twists.
- HIGH RESISTANCE** - Tensile and torsion strength. Antitheft and anti drilling.
- LOSS OF KEY SERVICE** - Duplication of keys in case of loss. Unique serial number.
- CERTIFICATION** - Sold Secure Silver / FUB - 2 roues.



### + K-TRAZ U13L

- LONG HANDLE** - Easy to attach.
- CERTIFICATION** - FUB - 1 roue.



### + K-TRAZ U13S

- COMPACT** - Can fits in a pocket.
- CERTIFICATION** - Sold Secure Silver.



Ref. 4946

Ref. 4945

## K-TRAZ U11

### // U-LOCK



- BASIC SECURITY** - Security level 11 - For areas with a very low risk of theft.
- Z SAFE** - Powerful double locking system and high resistance against impacts and twists.
- HIGH RESISTANCE** - Tensile and torsion strength. Antitheft and anti drilling.
- 2 KEYS INCLUDED** - In case of loss.
- QUICK MOUNTING** - Mounting clip.



Ref. 4922A

Ref. 4922B

### + K-TRAZ U11 CABLE



#### K-TRAZ U13

- > **TYPE** U-lock
- > **SECURITY LEVEL** 13
- > **MATERIAL**  
Hardened steel
- > **SECTION** Ø 13 mm
- > **MOUNTING** Adjustable on down tube - Ø from 20 to 42 mm
- > **KEYS (3 INCLUDED)**
- > **DIMENSIONS**  
180 x 275 x 35 mm  
S : 180 x 152 x 35 mm  
L : 177 x 340 x 35 mm
- > **WEIGHT**  
1.1 kg - S : 900g / L : 1.3 kg

#### K-TRAZ U11

- > **TYPE** U-lock
- > **SECURITY LEVEL** 11
- > **MATERIAL**  
Hardened steel
- > **SECTION** Ø 11mm
- > **FIXATION** Adjustable on down tube - Ø from 26 mm to 32 mm
- > **KEYS**  
2 included
- > **DIMENSIONS**  
165 x 287 x 36 mm
- > **WEIGHT** 850 g

#### K-TRAZ U11 CABLE

- > **TYPE** Antivol en U avec câble
- > **SECURITY LEVEL** 11
- > **MATERIAL**  
Hardened steel. Flexible twisted steel wire with a tough vinyl cable cover
- > **SECTION** Ø 11 mm (U) - Ø 10 mm (cable)
- > **FIXATION**  
Adjustable on down tube - Ø from 26 mm to 32 mm
- > **KEYS (2 INCLUDED)**
- > **DIMENSIONS**  
165 x 287 x 36 mm
- > **WEIGHT** 1.15 kg

## K-TRAZ M18

Ref. 4948

### // CHAIN BIKE LOCK WITH KEY PADLOCK

- +** **EBIKE LOCK - HIGH SECURITY** - Security level 18 - For areas with a high risk of theft.
- Z SAFE +** - Highly powerful quadruple locking system. Very high resistance to impact and torsion.
- PROTECTIVE COATING** - The chain is wrapped in a nylon cover to protect the bike's paintwork. Removable and washable.
- 3 KEYS INCLUDED** - Reproduction of keys in case of loss. Unique serial number.
- CERTIFICATIONS** - FUB - 2 roues / Sold Secure Gold.



## K-TRAZ M14

Ref. 4919

### // CHAIN LOCK

- +** **GOOD SECURITY** - security level 14 - For areas with a moderate risk of theft.
- Z SAFE** - Powerful double locking system. High resistance against impacts and twists.
- PROTECTIVE COATING** - The chain is encased in a fabric to protect the bike's paintwork.
- LOSS OF KEY SERVICE** - Duplication of keys in case of loss. Unique serial number.
- LONG LENGTH** - 120 cm to secure wheel and frame.



## K-TRAZ M12 CODE

Ref. 4918

### // CHAIN LOCK WITH CODE

- +** **GOOD SECURITY** - security level 12 - For areas with a moderate risk of theft.
- Z SAFE BALL** - Adjustable code locking system. High protection against robbery.
- 4 DIGIT COMBINAISON SYSTEM** - 10000 possible combinations.
- HIGH RESISTANCE** - Tensile and torsion strength. Antitheft and anti drilling.



#### K-TRAZ M18

- > **TYPE** Chain
- > **SECURITY LEVEL** 18
- > **MATERIAL** Hardened Steel
- > **SECTION** Chain link hexagonal section 10 x 10 x 10 mm
- > **MOUNTING** Wraps easily around the frame
- > **KEY / CODE** Key (3 included)
- > **DIMENSIONS** 580 x 130 x 50 mm
- > **WEIGHT** 3.25 kg

#### K-TRAZ M14

- > **TYPE** Chain Lock
- > **SECURITY LEVEL** 14
- > **MATERIAL** Hardened Steel
- > **SECTION** Chain link square section 8 x 8 mm
- > **MOUNTING** Wraps easily around the frame
- > **KEY / CODE** Key (3 included)
- > **DIMENSIONS** 120 x 650 x 45 mm
- > **WEIGHT** 2 kg

#### K-TRAZ M12 CODE

- > **TYPE** Chain lock with code
- > **SECURITY LEVEL** 12
- > **MATERIAL** Hardened Steel
- > **SECTION** Chain link square section 8 x 8 mm
- > **MOUNTING** Wraps easily around the frame
- > **KEY / CODE** Code
- > **DIMENSIONS** 40 x 420 x 35 mm
- > **WEIGHT** 1.25 kg

# K-TRAZ ZIP3

Ref. 4932

## // ZIP-TIE LOCK WITH CODE

K-Traz Zip3 is a self-locking code clamp with a steel blade that secures your bike or accessories such as a helmet or a bag. In town, it's an ideal addition to the main anti-theft device, such as a chain or U lock, to secure the bike's wheels or saddle.

Easy to store in a bag or pocket thanks to its low weight and compact size, it also helps prevent opportunistic theft during very short stops (a quick errand, a break during a ride, etc.).



**BASIC SECURITY** - Security level 3 - for areas with a very low risk of theft and short-term shutdown.

**3-DIGIT CYLINDER LOCK** - 1000 possible combinations.

**COMPACT** - Fits easily into a pocket.

**HIGH RESISTANCE** - 11 mm wide flat cable with coated steel blade for high strength.

# K-TRAZ M10

Ref. 4917

## // CHAIN LOCK



**BASIC SECURITY** - Security level 10 - For areas with a very low risk of theft.

**Z SAFE** - Powerful double locking system and high resistance against impacts and twists.

**TRANSPORT** - Wraps easily around the bike frame.

**PROTECTIVE COATING** - The chain is encased in a fabric to protect the bike's paintwork.

**2 KEYS INCLUDED** - In case of loss.

### + K-TRAZ M8

Ref. 4916

**BASIC SECURITY** - Security level 8 - For areas with a very low risk of theft.



K-TRAZ ZIP3

K-TRAZ M10

K-TRAZ M8

- > **TYPE** Zip lock
- > **SECURITY LEVEL** 3
- > **MATERIAL** Plastic coated flat steel
- > **SECTION** Section 3.5 x 11 mm length 450 mm
- > **KEY / CODE** Code
- > **DIMENSIONS** 135 x 210 x 15 mm
- > **WEIGHT** 86 g

- > **TYPE** Chain Lock
- > **SECURITY LEVEL** 10
- > **MATERIAL** Steel
- > **SECTION** Chain ring Ø 8 mm
- > **MOUNTING** Wraps easily around the frame
- > **KEY / CODE** 2 Keys
- > **DIMENSIONS** 80 x 430 x 27 mm
- > **WEIGHT** 1.2Kg

- > **TYPE** Chaîne
- > **SECURITY LEVEL** 8
- > **MATERIAL** Steel
- > **SECTION** Chain ring Ø 6 mm
- > **MOUNTING** Wraps easily around the frame
- > **KEY / CODE** 2 Keys
- > **DIMENSIONS** 430 x 80 x 27 mm
- > **WEIGHT** 700 g

## K-TRAZ F16

Ref. 4917A

### // FOLDING LOCK

- +** **GOOD SECURITY** - Security level 16 - For areas with a moderate risk of theft.
- Z SAFE** - Powerful double locking system. High resistance against impacts and twists.
- HIGH RESISTANCE** - Tensile and torsion strength. Antitheft and anti drilling.
- LOSS OF KEY SERVICE** - Duplication of keys in case of loss. Unique serial number.
- LONG LENGTH** - 71 cm unfolded.

### + K-TRAZ F16 L

Ref. 4917B

**VERY LONG LENGTH** - 95 cm unfolded.



## K-TRAZ CABLE

Ref. 4913A

### // CABLE

- +** **TOUGH VINYL COVER** - Vinyl coated to protect frame paintwork.
- VELCRO® STRAP** - Easy to transport using Velcro® fastening.

### + K-TRAZ CABLE L

Ref. 4913B

**EXTRA LONG** - Extra security for the wheels and saddle.

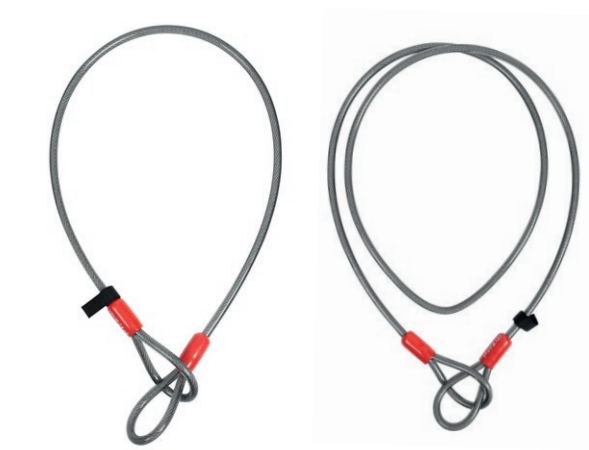

#### K-TRAZ F16

- > **TYPE** Folding lock
- > **SECURITY LEVEL** 16
- > **MATERIAL** Steel plates
- > **SECTION** 22 x 7 mm
- > **MOUNTING** Screw mounting or strap mounting
- > **KEY / CODE**  
Keys (3 included)
- > **DIMENSIONS**  
F16 : 62 x 186 x 45 mm  
F16 L : 80 x 186 x 45 mm
- > **WEIGHT** 1.1 kg / 1.35 kg

#### K-TRAZ CABLE

- > **TYPE** Cable
- > **MATERIAL** Flexible steel wire with a tough vinyl cable cover
- > **SECTION** Ø 10 mm
- > **DIMENSIONS**  
Cable : 1220 x 60 x 20 mm  
Cable L : 2200 x 55 x 20 mm
- > **WEIGHT** 300 g / 460 g



**K-TRAZ C9**

Ref. 4916A

**// CABLE LOCK WITH KEY****+ K-TRAZ C9 CODE**

Ref. 4916B

**K-TRAZ C6**

Ref. 4914A

**// CABLE LOCK WITH KEY****+ K-TRAZ C6 CODE**

Ref. 4914B

**K-TRAZ C8**

Ref. 4915A

**// CABLE LOCK WITH KEY****+ K-TRAZ C8 CODE**

Ref. 4915B



## K-TRAZ C9

- > **TYPE** Cable lock with key
- > **SECURITY LEVEL** 9
- > **MATERIAL** Flexible twisted steel wire with a tough vinyl cable cover
- > **SECTION** Ø 15 mm
- > **MOUNTING** Adjustable on down tube - Ø from 18 to 36 mm
- > **KEY / CODE**  
Key (3 included)  
Code
- > **DIMENSIONS**  
185 x 150 x 45 mm  
175 x 150 x 45 mm
- > **WEIGHT** 850 g / 740 g

## K-TRAZ C6

- > **TYPE** Cable lock with key
- > **SECURITY LEVEL** 6
- > **MATERIAL** Flexible twisted steel wire with a tough vinyl cable cover
- > **SECTION** Ø 12 mm
- > **MOUNTING** Adjustable on down tube - Ø from 22 to 30 mm
- > **KEY / CODE**  
Key (2 included)  
Code
- > **DIMENSIONS**  
150 x 170 x 35 mm  
150 x 185 x 35 mm
- > **WEIGHT** 410 g / 450 g

## K-TRAZ C8

- > **TYPE** Cable lock with key
- > **SECURITY LEVEL** 8
- > **MATERIAL** Flexible twisted steel wire with a tough vinyl cable cover
- > **SECTION** Ø 12 mm
- > **MOUNTING** Adjustable on down tube - Ø from 18 to 36 mm
- > **KEY / CODE**  
Key (3 included)  
Code
- > **DIMENSIONS**  
165 x 130 x 40 mm  
165 x 145 x 40 mm
- > **WEIGHT** 540 g / 560 g



**// HYDRATION**

## PULSE S2

### // SIDE-OPENING BOTTLE CAGE



**LIGHTWEIGHT AND STRONG** - Only 28 g for optimum bottle stability thanks to high-resistance carbon fibre.

**SIDE-OPENING** - Easier to introduce and take out the bottle. Right or left-mounted depending on model.

**ADJUSTABLE** - Wide adjustment range of 52 mm upwards or downwards.

**UNIVERSAL CYCLING BOTTLE** - Compatible to different bottle diameters from Ø 72 to 76 mm.

**COMES WITH SCREWS** - 7075T6 light aluminium.



Ref. 1755

Ref. 1756

## PULSE L2

Ref. 1770

### // SUPER LIGHTWEIGHT BOTTLE CAGE



**SUPER LIGHTWEIGHT** - Only 18 g.

**BOTTLE CAGE** - Highly resistant carbon fiber.

**TOP DESIGN** - Facilitates the insertion and extraction of the bottle.

**UNIVERSAL** - Adapts to different bottles from Ø 72 to 76 mm.

**COMES WITH SCREWS** - 7075T6 light aluminium.



PULSE S2

PULSE L2

- > **MATERIAL**  
Injected carbon fiber
- > **COLOR**  
Black
- > **WEIGHT**  
28 g
- > **MOUNTING**  
Left (ref. 1755) / Right (ref. 1756)
- > **SCREWS INCLUDED**
- > **DIMENSIONS (L x w x H)**  
76 x 85 x 151 mm

- > **MATERIAL**  
Injected carbon fiber
- > **COLOR**  
Black
- > **WEIGHT**  
18 g
- > **SCREWS INCLUDED**
- > **DIMENSIONS (L x w x H)**  
84 x 82 x 147 mm

> Used on the MTB XC World Cup circuit by



## TRI BOTTLE CAGE SET

Ref. 1708

### // DOUBLE SADDLE BOTTLE CAGE

- +** **UNIVERSAL MOUNTING ON SADDLE RAILS** - Fits all standard saddles with round rails.
- EASY ACCESS** - Optimum design for easy extraction and insertion of the bottle.
- ROBUST** - Reinforced fibre-glass material.
- ACCESSORIES HOLDERS** - 2 holders included for small inflators (like our EZ Big Shot) and a cartridge (16 or 25 g).



## PULSE Z2

Ref. 1705

### // REVERSIBLE BOTTLE CAGE FOR RIGHT OR LEFT HAND

- +** **REVERSIBLE** - Makes it easy to access the bottle. Right or left-hand mounting.
- ADAPTS TO ALL TYPES OF FRAME** - Ideal for eMTB, enduro MTB, gravel.
- ADJUSTABLE** - Wide adjustment range of 22 mm upwards or downwards.
- UNIVERSAL** - Compatible with Ø 72 to 76 mm water bottles.
- ROBUST** - Reinforced fibre-glass material.



#### TRI BOTTLE CAGE SET

- > **MATERIAL**  
Glass fibre-reinforced polyamide
- > **COLOURS**  
Black
- > **WEIGHT**  
196 g
- > **SCREWS INCLUDED**
- > **DIMENSIONS (L x w x H)**  
187 x 127 x 147 mm

#### PULSE Z2

- > **MATERIAL**  
Glass fibre-reinforced polyamide
- > **COLOURS**  
Black
- > **WEIGHT**  
40 g
- > **SCREWS INCLUDED**
- > **DIMENSIONS (L x w x H)**  
84 x 82 x 147 mm

## PULSE Z2 & SENSE PRO

Ref. 1557

### // REVERSIBLE BOTTLE CAGE AND 500 ML BOTTLE SET



**ADAPTS TO ALL TYPES OF FRAME** - Ideal for eMTB, enduro MTB, gravel.



## PULSE Z2i

Ref. 1706

### // REVERSIBLE BOTTLE CAGE WITH 2 ADDITIONAL HOLDERS



**REVERSIBLE** - Makes it easy to access the bottle. Right or left-hand mounting.

**ADAPTS TO ALL TYPES OF FRAME** - Ideal for eMTB, enduro MTB, gravel.

**CO2 HOLDER** - For smaller inflators (like our EZ Big Shot) and a cartridge (16 or 25 g).

**UNIVERSAL HOLDER** - For accessories Ø 20 to 32 mm.

**ROBUST** - Reinforced fibre-glass material.



Ref. 1707



PULSE Z2 &amp; SENSE PRO 50

- > **BOTTLE CAGE MATERIAL**  
Glass fibre-reinforced polyamide
- > **COLOURS** Black
- > **SCREWS INCLUDED**
- > **BOTTLE MATERIAL** Polypropylene
- > **CAP MATERIAL**  
Polypropylene and elastomer. Valve and Nozzle made with food-grade silicon.
- > **COLOURS** Smoked Black (grey) 1554
- > **BPA-FREE OR OTHER TOXINS**
- > **DIMENSIONS (L x w x H)**  
84 x 90 x 170 mm
- > **WEIGHT**  
107 g

PULSE Z2i

- > **MATERIAL**  
Glass fibre-reinforced polyamide
- > **COLOURS**  
Black
- > **WEIGHT**  
62 g
- > **STRAP**  
Nylon with silicone
- > **SCREWS INCLUDED**
- > **DIMENSIONS (L x w x H)**  
85 x 100 x 147 mm

# PULSE A2

Ref. 1741 → 1748

## // LIGHT BOTTLE CAGE

With the Pulse A2, we offer top quality at the best price. With its sleek, crafted finish, it is lighter than the majority of carbon bottle cages, while offering an excellent hold on the bottle. The elastomer clasp ensures a strong hold on the bottle.



- +** **LIGHTWEIGHT** - Only 26 g.
- ELASTOMER CLASP** - Holds the bottle and limits vibrations.
- OPTIMAL DESIGN** - Easy bottle insertion and removal.
- UNIVERSAL CYCLING BOTTLE** - Adapts to different bottle diameters.

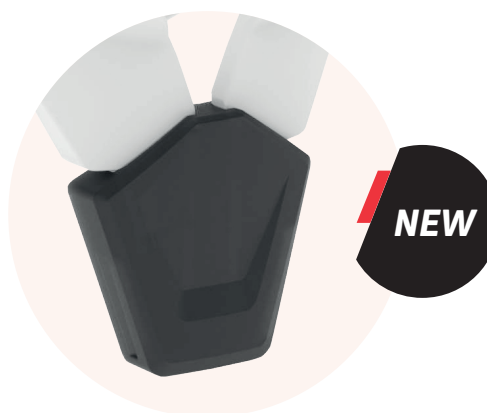

- > **MATERIAL**  
Polyamide and elastomer clasp
- > **WEIGHT**  
26 g
- > **DIMENSIONS (L x W x h)**  
80 x 86 x 147 mm
- > **COLOURS**  
White/black (1747)  
Black/black (1741)  
Red/black (1742)  
Yellow/black (1744)  
Orange/black (1746)  
Gray/black (1743)  
Blue/black (1745)  
Purple/black (1748)

## PULSE B2

Ref. 1780 → 1789

### // BI-MATERIAL BOTTLE CAGE



**LIGHTWEIGHT** - Only 30 g.

**BI-MATERIAL** - Resistant material at its centre. Light and flexible on the outside.

**OPTIMAL DESIGN** - Easy bottle insertion and removal.

**UNIVERSAL** - Adapts to different bottle diameters.

**CUSTOM** - Available in 10 colours to match your bike.



## BOTTLE CAGE MOUNT

Ref. 1795

### // BOTTLE CAGE WITH BUILT-IN UNIVERSAL MOUNT



**E-BIKE FRIENDLY** - For bikes that have no studs for bottle cages.

**UNIVERSAL MOUNT** - Can be fitted on handlebars, stems or seat posts. Ø 22 à 34 mm.

**ADJUSTABLE MOUNT** - Possible to adjust it before mounting.

**BI-MATERIAL BOTTLE CAGE** - Resistant material at its centre. Light and flexible on the outside.

**OPTIMAL DESIGN** - Easy bottle insertion and removal.



PULSE B2

- > **MOUNTING SYSTEM MATERIAL**  
Bi-component polyamide
- > **COLOURS**  
Black (1780), Grey (1781), White (1782), Blue (1783), Cyan Blue (1784), Green (1785), Neon Yellow (1786), Orange (1787), Pink (1788), Red (1789)
- > **WEIGHT**  
30 g
- > **SCREWS INCLUDED**
- > **DIMENSIONS (L x w x H)**  
80 x 80 x 145 mm

BOTTLE CAGE MOUNT

- > **MOUNTING SYSTEM MATERIAL**  
Technopolymer
- > **BOTTLE CAGE MATERIAL**  
Bi-component polyamide
- > **COLOURS**  
Black
- > **WEIGHT**  
80 g
- > **DIMENSIONS (L x w x H)**  
145 x 80 x 145 mm

# Z ADVENTURE CAGE

Ref. 1796

## // UNIVERSAL BOTTLE CAGE

- +** **UNIVERSAL MOUNTING** - On frame or fork, thanks to the 4 fixing holes allowing a great adaptability.
- COMPATIBILITY** - Accepts bottles from Ø 66 to 92 mm.
- SECURITY** - Tightening by wide Hypalon hook and loop strap.
- ROBUST** - Fiber reinforced polypropylene support.
- LIGHTNESS** - CAD and openwork design validated by digital simulation.



# GIZMO

Ref. 1083

## // UNIVERSAL BOTTLE CAGE MOUNTING SYSTEM

- +** **UNIVERSAL MOUNTING** - For Ø from 15 to 75 mm.
- STABLE AND SECURE** - Anti-slip function and reinforced protection thanks to the soft wristband.
- E-BIKE FRIENDLY** - For bikes that have no studs for bottle cages.



### Z ADVENTURE CAGE

- > **MATERIAL**  
Injected support in fibre reinforced polypropylene and Hypalon strap
- > **COLOURS**  
Black
- > **WEIGHT**  
88 g
- > **SCREWS INCLUDED**
- > **DIMENSIONS (L x w x H)**  
81 x 94 x 230 mm

### GIZMO

- > **MATERIAL**  
Polypropylene and thermoplastic elastomer / steel screws and nuts
- > **WEIGHT**  
2 x 25 g
- > **FOR TUBE Ø** 15 mm > 75 mm
- > **SCREWS INCLUDED**
- > **DIMENSIONS (L x w x H)**  
40 x 143 x 18 mm



## PULSE FULL ALU

Ref. 1730 → 1732

### // ALUMINIUM BOTTLE CAGE

- +** **ALL ALUMINIUM** - Durability, lightness and high corrosion resistance.
- GOOD HOLD** - The bottle is well maintained on the bike.



## VINTAGE

Ref. 1720

### // VINTAGE BOTTLE CAGE

- +** **ZÉFAL KNOW-HOW** - Experience since 1880.
- GOOD HOLD** - The bottle is well maintained on the bike.



## ALU PLAST 124

Ref. 1240A → 1240G

### // WIRE ALUMINIUM BOTTLE CAGE

- +** **IN ALUMINIUM AND TECHOPOLYMER** - The right combination between rigidity and flexibility.
- T-SHAPED DESIGN** - For a secure hold of the bottle on the bike.



PULSE FULL ALU

VINTAGE

ALU PLAST 124

- > **MATERIAL**  
Aluminium
- > **COLOURS**  
Silver (1730), Black (1731), White (1732)
- > **WEIGHT**  
40 g
- > **DIMENSIONS (L x w x H)**  
85 x 85 x 117 mm

- > **MATERIAL**  
Chromed steel with vegetable leather cover
- > **COLOURS**  
Silver and brown
- > **WEIGHT**  
80 g
- > **DIMENSIONS (L x w x H)**  
77 x 91 x 150 mm

- > **MATERIAL**  
Aluminium
- > **COLOURS**  
Black (1240A), Red (1240B), Blue (1240C), Yellow (1240D), Orange (1240E), White (1240F), Silver (1240G)
- > **WEIGHT**  
40 g
- > **DIMENSIONS (L x w x H)**  
80 x 90 x 152 mm

## MAGNUM PRO

Ref. 1640 - 1641

### // PREMIUM HIGH CAPACITY BOTTLE

- +** **PRO-CAP** - Double-closure system for 100% watertight transport.
- SOFT NOZZLE** - Pleasant feeling in the mouth.
- GRIP RING** - Over-moulded cover for better grip on the bottle.
- ODOURLESS MATERIAL** - The polypropylene material keeps water clean and pure.
- BPA-FREE** - No Bisphenol-A, phtalates or other toxins used.



## MAGNUM

Ref. 1643

### // HIGH CAPACITY BOTTLE

- +** **SOFT-CAP** - Easy and convenient to use.
- SOFT NOZZLE** - Soft nozzle for a pleasant sensation while drinking.
- HIGH CAPACITY BOTTLE** - 975 ml.
- ODOURLESS MATERIAL** - The polypropylene material keeps water clean and pure.
- BPA-FREE** - No Bisphenol-A, phtalates or other toxins used.



#### MAGNUM PRO

- > **MATERIAL** Polypropylene
- > **CAP MATERIAL** Polypropylene and elastomer. Valve and Nozzle made with food-grade silicon.
- > **CAP** Pro-Cap
- > **COLOURS** Smoked black (grey /blue) 1640, White (black/red) 1641
- > **CAPACITY** 975 ml / 33 oz
- > **DIAMETER** 76 mm
- > **WEIGHT** 92 g
- > **DIMENSIONS (L x w x H)** 78 x 78 x 270 mm
- > **BPA-FREE OR OTHER TOXINS**

#### MAGNUM

- > **MATERIAL** Polypropylene
- > **CAP MATERIAL** Polypropylene / Nozzle made with food-grade silicon
- > **CAP** Soft-Cap
- > **COLOURS** Translucent
- > **CAPACITY** 975 ml / 33 oz
- > **DIAMETER** 76 mm
- > **WEIGHT** 85 g
- > **DIMENSIONS (L x w x H)** 78 x 78 x 263 mm
- > **BPA-FREE OR OTHER TOXINS**

## SENSE PRO 50

Ref. 1554 → 1557

### // 500 ML PREMIUM BOTTLE



**ADAPTS TO ALL TYPES OF FRAME** - Designed for frames missing access (electric MTB, enduro MTB, Gravel).

**PRO-CAP** - Double-closure system for 100% watertight transport.

**SOFT NOZZLE** - Pleasant feeling in the mouth.

**ODOURLESS MATERIAL** - The polypropylene material keeps water clean and pure.

**BPA-FREE** - No Bisphenol-A, phtalates or other toxins used.



## SENSE PRO 65 & 80

### // PREMIUM BOTTLE



**PRO-CAP** - Double-closure system for 100% watertight transport.

**SOFT NOZZLE** - Pleasant feeling in the mouth.

**GRIP RING** - Over-moulded cover for better grip on the bottle.

**ODOURLESS MATERIAL** - The polypropylene material keeps water clean and pure.

**BPA-FREE** - No Bisphenol-A, phtalates or other toxins used.



#### SENSE PRO 50

- > **MATERIAL** Polypropylene
- > **CAP MATERIAL** Polypropylene and elastomer. Valve and Nozzle made with food-grade silicon.
- > **CAP** Pro-Cap
- > **COLOURS** Smoked Black (grey) 1554, Smoked Black (green) 1555, Smoked Black (blue) 1556
- > **CAPACITY** 500 ml / 17 oz
- > **DIAMETER** 76 mm
- > **WEIGHT** 67 g
- > **DIMENSIONS (L x w x H)** 78 x 78 x 163 mm
- > **BPA-FREE OR OTHER TOXINS**

#### SENSE PRO 65

- > **MATERIAL** Polypropylene
- > **CAP MATERIAL** Polypropylene and elastomer. Valve and Nozzle made with food-grade silicon.
- > **CAP** Pro-Cap
- > **COLOURS** Black (copper/grey) 1455, Smoked black (black/grey) 1456 / Translucide (gray/dark green) 1457 / White (double gray) 1458
- > **CAPACITY** 650 ml / 22 oz
- > **DIAMETER** 74 mm
- > **WEIGHT** 79 g
- > **DIMENSIONS (L x w x H)** 76 x 76 x 204 mm
- > **BPA-FREE OR OTHER TOXINS**

#### SENSE PRO 80

- > **COLOURS** Black (copper/grey) 1465 / Smoked black (black/grey) 1466 / Translucide (gray/dark green) 1467 / White (double grey) 1468
- > **CAPACITY** 800 ml / 27 oz
- > **DIAMETER** 74 mm
- > **WEIGHT** 85 g
- > **DIMENSIONS (L x w x H)** 76 x 76 x 240 mm
- > **BPA-FREE OR OTHER TOXINS**

## SENSE SOFT NO MUD 65 & 80

### // PERFORMANCE BIKE BOTTLE WITH VALVE PROTECTION

- +** **SOFT-CAP** - Easy and convenient to use.
- SOFT NOZZLE** - Pleasant feeling in the mouth.
- MUD CAP** - Keeps your drink pure.
- EASY CLEANING** - Removable valve and bottle with wide opening.
- ODOURLESS MATERIAL** - The polypropylene material keeps water clean and pure.
- BPA-FREE** - No Bisphenol-A, phtalates or other toxins used.



Ref. 157P-Q-R

Ref. 155P-Q-R

## SENSE SOFT 65 & 80

### // PERFORMANCE BIKE BOTTLE

- +** **SOFT-CAP** - Easy and convenient to use.
- SOFT NOZZLE** - Pleasant feeling in the mouth.
- EASY CLEANING** - Removable valve and bottle with wide opening.
- ODOURLESS MATERIAL** - The polypropylene material keeps water clean and pure.
- BPA-FREE** - No Bisphenol-A, phtalates or other toxins used.



155K-L-M-N

157K-L-M-N



#### SENSE SOFT NO MUD

- > **MATERIAL** Polypropylene
- > **CAP MATERIAL** Polypropylene / Nozzle and mud cap made with food-grade silicon.
- > **CAP** Soft-Cap
- > **COLOURS 65 = 155 / 80 = 157** Smoked Black (grey / black) 155P, Transparent (green / grey) 155Q, Blanc (pink / grey) 155R
- > **CAPACITY** 800 ml / 27 oz - 650 ml / 22 oz
- > **DIAMETER** 74 mm
- > **WEIGHT** 87 g / 80 g
- > **DIMENSIONS (L x w x H)** 76 x 76 x 244 mm - 76 x 76 x 210 mm
- > **BPA-FREE OR OTHER TOXINS**

#### SENSE SOFT

- > **MATERIAL** Polypropylene
- > **CAP MATERIAL** Polypropylene / Nozzle and mud cap made with food-grade silicon
- > **CAP** Soft-Cap
- > **COLOURS 65 = 155 / 80 = 157** Black (155K), Translucent Blue (155L), Olive Green (155M), Neon Yellow (155N)
- > **CAPACITY** 800 ml / 27 oz - 650 ml / 22 oz
- > **DIAMETER** 74 mm
- > **WEIGHT** 78 g - 71 g
- > **DIMENSIONS (L x w x H)** 76 x 76 x 240 mm - 76 x 76 x 206 mm
- > **BPA-FREE OR OTHER TOXINS**

## ARCTICA PRO 55 & 75

### // INSULATED BOTTLE



**MULTI LAYER INSULATED SYSTEM** - High performance insulated system for keeping the temperature over 2.5 hrs.

**PRO-CAP** - Double-closure system for 100% watertight transport.

**SOFT NOZZLE** - Pleasant feeling in the mouth.

**ODOURLESS MATERIAL** - The polypropylene material keeps water clean and pure.

**BPA-FREE** - No Bisphenol-A, phtalates or other toxins used.



Ref. 1667 → 1669

Ref. 1677 → 1679

## ARCTICA 55 & 75

### // INSULATED BOTTLE



**MULTI LAYER INSULATED SYSTEM** - High performance insulated system for keeping the temperature over 2.5 hrs.

**ODOURLESS MATERIAL** - The polypropylene material keeps water clean and pure.

**BPA-FREE** - No Bisphenol-A, phtalates or other toxins used.



Ref. 1660 → 1665

Ref. 1670 → 1675



#### ARCTICA PRO

- > **MATERIAL** Polypropylene
- > **CAP MATERIAL** Polypropylene / Nozzle and mud cap made with food-grade silicon
- > **CAP** Pro-Cap
- > **COLOURS 55**: Blue (1667), Black (1668), Red (1669)
- > **75**: Blue (1677), Black (1678), Red (1679)
- > **INSULATING MATERIAL** Outside: metallic PET and polyethylene foam / Inside: white PE
- > **INSULATION** 2h30
- > **MAXIMUM BEVERAGE T°** 80°C - 176°F max
- > **CAPACITY** 550 ml / 18 oz - 750 ml / 25 oz
- > **DIAMETER** 74 mm
- > **WEIGHT** 110 g - 134 g
- > **DIMENSIONS (L x w x H)**  
76 x 76 x 216 mm - 76 x 76 x 268 mm
- > **BPA-FREE OR OTHER TOXINS**

#### ARCTICA

- > **MATERIAL** Polypropylene
- > **CAP MATERIAL** Polypropylene / Nozzle and mud cap made with food-grade silicon
- > **CAP** Grip-Cap
- > **COULEURS** Black (1660/1670), Blue (1661/1671), Carabbean green (1662/1672), Red (1663/1673), Orange (1664/1674), Light pink (1665/1675)
- > **INSULATING MATERIAL** Outside: metallic PET and polyethylene foam / Inside: white PE
- > **INSULATION** 2h30
- > **MAXIMUM BEVERAGE T°** 80°C - 176°F max
- > **CAPACITY** 550 ml / 18 oz - 750 ml / 25 oz
- > **DIAMETER** 74 mm
- > **WEIGHT** 93 g - 116 g
- > **DIMENSIONS (L x w x H)**  
76 x 76 x 210 mm - 76 x 76 x 260 mm
- > **BPA-FREE OR OTHER TOXINS**

# Z HYDRO ENDURO

Ref. 7098

## // 9L HYDRATION PACK WITH 3L RESERVOIR

The Z Hydro Enduro is the ideal hydration bag for day-long rides. It features a high-performance 3-litre water bag with a wide opening for easy filling and cleaning. Its silicone bite nozzle will ensure a comfortable and safe hydration for throughout your ride. This high-capacity backpack is ideal for carrying all the gear and equipment you need for mountain biking. You can store your tools (pump, multi-tools, tyre levers, inner tubes, etc.), personal belongings (smartphone, key) or nutrition in separate pockets. You'll also enjoy the modularity of the expandable net for clothes and protective equipment, and the special helmet attachment system. Equipped with a waist belt, chest strap and 3D foam reinforcements, it adapts to most body shapes, offering perfect stability, even on the roughest terrain.



**+** **VOLUME** - 3L PEVA water bladder without Bisphenol-A, phthalates or other toxins for clean and pure water.

**RESISTANT MATERIALS** - 300D polyester fabric and ripstop.

**CAPACITY STORAGE** - Organised & modular. 1 separate pocket for water bladder + 1 main pocket with 3 mesh inner compartments + 1 padded pocket for smartphone or glasses + 1 easy-access XL zipped outside pocket + 1 external stretch net + 1 special helmet attachment system.

**COMFORTABLE** - Folder and straps in 3D foam.

**UNIVERSAL** - Adjustable chest strap, waist strap and shoulder straps to suit different body shapes for perfect fit.



- > **CAPACITY BAG** 9L with 3L water bladder
- > **MATERIAL BAG** Polyester / Ripstop Nylon fabric
- > **CAPACITY STORAGE** 5 with 3 zipped pockets
- > **COLOURS** Black
- > **STRAPS** Adjustable chest strap, waist strap, shoulder straps
- > **DIMENSIONS (L x w x h)** 460 x 240 x 120 mm
- > **WEIGHT** 550 g
- > **CAPACITY RESERVOIR** 3 L
- > **MATERIAL RESERVOIR** PEVA
- > **HOSE LENGTH** 1 m
- > **WEIGHT** 130 g
- > **BPA-FREE OR OTHER TOXINS**
- > **DIMENSIONS (L x W)** 435 x 200 mm



## Z HYDRO XC Ref. 7097

### // 6L HYDRATION PACK WITH 2L RESERVOIR



**VOLUME** - 2L PEVA water bladder without Bisphenol-A, phthalates or other toxins for clean and pure water.

**RESISTANT MATERIALS** - 300D polyester fabric and ripstop.

**CAPACITY STORAGE** - Organised. 1 main pocket with divider for water bladder and mesh compartments + 1 padded pocket for smartphone or glasses + 1 easy-access external zipped pocket + 1 external stretch mesh.

**COMFORTABLE** - Folder and straps in 3D foam.

**UNIVERSAL** - Adjustable chest strap, waist strap and shoulder straps to suit different body shapes for perfect fit.



## Z HYDRO RACE Ref. 7099

### // 3L HYDRATION PACK WITH 1.5L RESERVOIR



**VOLUME** - 1.5 L PEVA water bladder without Bisphenol-A, phthalates or other toxins for clean and pure water.

**LIGHTWEIGHT AND DURABLE** - Ripstop polyester fabric.

**BREATHABLE** - Folder and straps in 3D mesh for good moisture.

**CAPACITY STORAGE** - Minimalist. 1 water bladder pocket separately + 1 front pocket XL, padded, secure and easy to access.

**UNIVERSAL** - Adjustable chest strap and shoulder straps to suit different body shapes for perfect fit.



#### Z HYDRO XC

- > **CAPACITY BAG** 6L with 2L water bladder
- > **MATERIAL BAG** Polyester / Ripstop Nylon fabric
- > **CAPACITY STORAGE** 4 with 3 zipped pockets
- > **COLOURS** Black
- > **STRAPS** Adjustable chest, waist and shoulder straps
- > **DIMENSIONS (Lxwxh)** 400 x 220 x 110 mm
- > **WEIGHT** 370 g
- > **CAPACITY RESERVOIR** 2 L
- > **MATERIAL RESERVOIR** PEVA
- > **HOSE LENGTH** 1 m
- > **WEIGHT** 120 g
- > **BPA-FREE OR OTHER TOXINS**
- > **DIMENSIONS (LxW)** 390 x 180 mm

#### MAGNUM

- > **CAPACITY BAG** 3L with 1.5L water bladder
- > **MATERIAL BAG** Polyester / Ripstop Nylon fabric
- > **CAPACITY STORAGE** 2 with 1 zipped pocket
- > **COLOURS** Black
- > **STRAPS** Adjustable chest strap
- > **DIMENSIONS (Lxwxh)** 370 x 180 x 60 mm
- > **WEIGHT** 174 g
- > **CAPACITY RESERVOIR** 1.5 L
- > **MATERIAL RESERVOIR** PEVA
- > **HOSE LENGTH** 1 m
- > **WEIGHT** 115 g
- > **BPA-FREE OR OTHER TOXINS**
- > **DIMENSIONS (LxW)** 360 x 175 mm



**// PROTECTION**



# DEFLECTOR FM 40

Ref. 2504

## // MTB FRONT MUDGUARD

The Deflector FM40 mudguard can be fitted to the front of a mountain bike or electric bike to effectively protect the bike and rider from water and mud splashes. The self-gripping, rubberised straps make fitting simple, effective and universal. Its elegant, discreet design blends in perfectly with the aesthetics of your bike, without compromising its stability.

The Deflector FM40 is particularly suitable for wide tyres up to 3.0". It is made from impact-resistant engineering plastic. The side deflectors offer unique protection for the fork tubes against dirt. Its length and stability mean you can ride with peace of mind, whatever your riding style and whatever the weather conditions. The mudguard can also be fixed-mounted using an adapter for forks with threaded holes in the rear of the fork bridge. Two optional models are available: the FZ01 compatible with Fox forks from 2021, Suntour, X-Fusion, Öhlins and Marzocchi (with Fox chassis), and the RZ01 for Rockshox Zeb, Domain (2021) and Lyrik, Pike (from 2023), Recon, 35 Gold and Silver.



**EFFICIENT AND DISCREET** - Effective, discreet mudguard positioned close to the wheel.

**UNIVERSAL** - With adjustable straps. Particularly suitable for wide tyres up to 3.0".

**STABLE AND ROBUST** - Thanks to its technical plastic construction and three fixing points.

**FORK PROTECTION** - Side deflectors to protect fork seals from dirt.

**BOLT-ON ADAPTER** - Fixed mounting fit to your fork by choosing the appropriate adapter.



- > **MATERIAL**  
Polypropylene
- > **WHEEL DIAMETER**  
27.5" / 28" / 29"
- > **MAXIMUM RECOMMENDED TYRE WIDTH**  
Up to 3.0" / 76 mm
- > **PROTECTION LEVEL**  
High
- > **MOUNTING**  
On the fork with straps included :  
X2 strap 210 mm  
X1 strap 150 mm
- > **WEIGHT**  
510 g
- > **DIMENSIONS (L x W x h)**  
560 x 90 x 170 mm



Ref. 2401

**FZ01 ADAPTER FOR DEFLECTOR FM40**  
Compatible with Fox, Öhlins, X-Fusion, Suntour, Marzocchi with chassis Fox.



Ref. 2451

**RZ01 ADAPTER FOR DEFLECTOR FM40**  
Compatible with Zeb, Domain (2021), Lyrik, Pike (from 2023), Recon, 35 Gold & Silver.

## DEFLECTOR FM20

Ref. 2552

### // MTB FRONT MUDGUARD

**+** **EFFICIENT AND DISCRETE** - Efficient whilst discrete thanks to its proximity to the ground.

**UNIVERSAL** - Compatible with most of the forks (standard and boost wheel hub).

**2 MOUNTING SYSTEMS INCLUDED** - Snap-On by Velcro® or zip-ties.

**CUSTOMIZABLE** - 3 stickers included.



### + DEFLECTOR FM30

Ref. 2554

**EASY TO FIT AND ROBUST** - Fitted using zip-ties with soft covers for perfect hold and protection of the fork paintwork.

## DEFLECTOR FM60

Ref. 2500

**+** **UNIVERSAL** - Compatible with most of the telescopic forks.

**QUICK REMOVAL** - After first mounting, the mudguard can be easily removed for carrying the bike.



FM20

- > **MATERIAL** Polypropylene
- > **WHEEL DIAMETER** 26" / 27.5" / 29"
- > **MAXIMUM RECOMMENDED TYRE WIDTH** 2.4"
- > **PROTECTION LEVEL** Minimal
- > **MOUNTING** X4 zip-ties or X4 Velcro® starps included
- > **WEIGHT** 110 g
- > **DIMENSIONS (L x w x H)** 360 x 78 x 145 mm

FM30

- > **MATERIAL** Polypropylene
- > **WHEEL DIAMETER** 26" / 27.5" / 27.5"+ / 29"
- > **MAXIMUM RECOMMENDED TYRE WIDTH** 2.6"
- > **PROTECTION LEVEL** High
- > **MOUNTING** On the front fork with 6 zip-ties® included
- > **WEIGHT** 135 g
- > **DIMENSIONS (L x w x H)** 475 x 88 x 170 mm

FM60

- > **MATERIAL** Polypropylene
- > **WHEEL DIAMETER** 26" / 27.5"
- > **MAXIMUM RECOMMENDED TYRE WIDTH** 2.6"
- > **PROTECTION LEVEL** High
- > **MOUNTING** On the fork steerer Adjustable for Ø from 20 to 33.7 mm
- > **WEIGHT** 145 g
- > **DIMENSIONS (L x w x H)** 660 x 73 x 150 mm
- > **AVAILABLE IN SET** Deflector RM60 (set: #2509)

## KID MTB MUDGUARD SET

Ref. 2501

### // MUDGUARD SET FOR CHILDREN'S MOUNTAIN BIKES

- +** **16", 18" OR 20" WHEELS** - For children's bikes.
- QUICK MOUNTING** - Easy and quick installation and remove, no tools required.
- UNIVERSAL** - Compatible with all types of bicycle frames.
- CUSTOMIZABLE** - Stickers included.



## DEFLECTOR LITE FRONT

Ref. 2506

### // LIGHT MTB FRONT MUDGUARD

- +** **LIGHT** - Light and discreet mudguard.
- FACE PROTECTION** - Design studies to prevent spray on the face.
- FORK PROTECTION** - Side spoilers to protect the sheaths from rising mud.
- UNIVERSAL** - Compatible with most forks on the market.
- PAINT PROTECTION** - «Skin Armor» protective strips included.



## DEFLECTOR LITE FRONT XL

Ref. 2553



KID MTB

LITE FRONT

LITE XL

- > **MATERIAL** Polypropylene
- > **WHEEL DIAMETER** 16" / 18" / 20"
- > **MAXIMUM RECOMMENDED TYRE WIDTH** 2.2"
- > **PROTECTION LEVEL** High
- > **MOUNTING** Front : MD-Quick (X2 Elastic straps 165 mm) on down tube - Adjustable until Ø75mm. Rear : Saddle-rail mounting.
- > **WEIGHT** 129 g
- > **DIMENSIONS (L x w)** 340 x 114 x 40 mm - Front : 340 x 80 - 60 mm / Rear : 288 x 114 - 94 mm

- > **MATERIAL** Polypropylene
- > **WHEEL DIAMETER** 26" / 27.5" / 29"
- > **MAXIMUM RECOMMENDED TYRE WIDTH** 3.0"
- > **PROTECTION LEVEL** Minimal
- > **MOUNTING** X6 zip-ties included
- > **WEIGHT** 27g / 32g with zip-ties
- > **DIMENSIONS (L x w)** 270 x 276 mm

- > **MATERIAL** Polypropylene
- > **WHEEL DIAMETER** 26" / 27.5" / 29" / 27.5"+ / 29"+ / Fat Bike
- > **MAXIMUM RECOMMENDED TYRE WIDTH** 4.0"
- > **PROTECTION LEVEL** Minimal
- > **MOUNTING** X7 zip-ties included
- > **WEIGHT** 48 g with zip-ties
- > **DIMENSIONS (L x w)** 286 x 300 mm

## DEFLECTOR RM60

Ref. 2505

### // REAR MTB MUDGUARD

- +** **MD-TURN SYSTEM** - Quick screw-on mounting system on seat post. Adjustable from Ø 25 - 32 mm.
- ADJUSTABLE** - Ensures an optimal protection.
- DUAL MATERIAL SPOILER** - Better protection and brings flexibility to the fender.
- VISIBILITY** - Reflective ring for a better visibility by night.

### + DEFLECTOR RM60+

Ref. 2507

- DOUBLE ORIENTATION** - Optimal tyre coverage.



## DEFLECTOR RM90+

Ref. 2532

### // REAR MTB MUDGUARD FOR WIDE TYRES

## SHIELD S20

Ref. 2563

### // REAR-WHEEL, SADDLE-MOUNTED MTB MUDGUARD

- +** **LIGHT AND DISCREET** - Very light mudguard.
- QUICK MOUNTING** - Easy and quick installation and remove, no tools required.
- DOUBLE LOCK** - Double-locking system under the saddle.
- UNIVERSAL** - Compatible with all standard-rail saddles.



RM60 / RM60+

- > **MATERIAL** Technopolymer
- > **WHEEL DIAMETER** 26" / 27.5"
- > **MAXIMUM RECOMMENDED TYRE WIDTH** 2.6"
- > **PROTECTION LEVEL** High / Maximal
- > **MOUNTING** MD-Turn - On seat post
- > **WEIGHT** 166 g / 220 g
- > **DIMENSIONS (L x W x H)** 570 x 72 - 80 x 120 mm  
630 x 72 - 80 x 120 mm
- > **AVAILABLE IN SET** Deflector FM60 (set: #2509)

RM90+

- > **MATERIAL** Technopolymer
- > **WHEEL DIAMETER** 26" / 27.5" / 27.5"+ / 29"
- > **MAXIMUM RECOMMENDED TYRE WIDTH** 2.8"
- > **PROTECTION LEVEL** Maximal
- > **MOUNTING** MD-Turn - On seat post
- > **WEIGHT** 238 g
- > **DIMENSIONS (L x W x H)** 640 x 85 - 90 x 110 mm

SHIELD S20

- > **MATERIAL** Polypropylene
- > **WHEEL DIAMETER** 26" / 27.5" / 29"
- > **MAXIMUM RECOMMENDED TYRE WIDTH** 2.8"
- > **PROTECTION LEVEL** Minimal
- > **MOUNTING** Saddle-rail mounting
- > **WEIGHT** 67 g
- > **DIMENSIONS (L x W x H)** 288 x 114 - 94 x 30 mm

# DEFLECTOR RS75

Ref. 2534

## // REAR MTB MUDGUARD

The Deflector RS75 is the right protection for all mountain bikes. Thanks to its quick mounting close to the wheel, it is both discreet and effective. The Deflector RS75 is also suitable for full-suspension bikes with telescopic seatposts, thanks to its swingarm mounting.



### **ADJUSTABLE UNIVERSAL MOUNT -**

Quick to install and remove.

### **SPECIAL FULL-SUSPENSION BIKE -**

Mounted on the frame or swingarm, close to the wheel. Compatible with telescopic seatposts.

**FOR WIDE TYRES -** 26" / 27.5" / 27.5+ / 29" tyres up to 2.8".

**FRAME PROTECTION -** Soft pads and silicone-coated straps to protect paintwork.

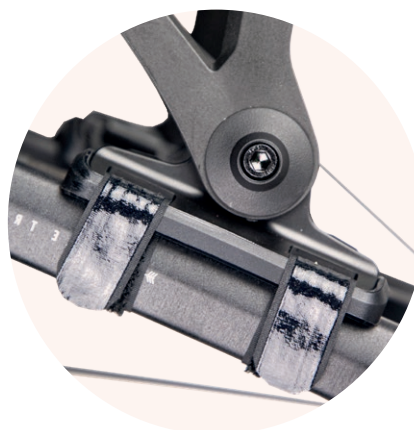

### > **MATERIAL**

Technopolymer (PP + 20% FG)

### > **WHEEL DIAMETER**

26" / 27.5" / 27.5+ / 29"

### > **MAXIMUM RECOMMENDED TYRE WIDTH**

2.8"

### > **PROTECTION LEVEL**

Maximal

### > **MOUNTING**

MD-Strap - For  $\varnothing$  10 to 32 mm / strap length = 150 mm

### > **WEIGHT**

310 g

### > **DIMENSIONS (L x w x h)**

663 x 80 x 290 mm

# DEFLECTOR M65 SET

Ref. 2525

## // MTB MUDGUARD SET

The Deflector M65 is a set of front and rear mudguards for mountain bikes, suitable for use on all types of terrain or for daily commuting in town. The universal MD-Strap mounting system allows easy installation on the rear frame and front fork.

The height of the mudguards can be adjusted to position the mudguard close to the wheel, whatever the type of bike: mountain bikes with or without electric assistance, semi-rigid or full-suspension, etc. The design is suitable for tyres up to 2.6" wide, so you'll be protected from splashes of rain and mud.



- +** **UNIVERSAL** - Fits all bikes with wide tyres up to 2.6".
- QUICK MOUNTING** - Adjustable straps for mounting on frame and suspension fork.
- STABLE AND ROBUST** - Reinforced plastic design and construction.
- ADJUSTABLE** - Adjustable height for optimal protection.
- FRAME AND FORK PROTECTION** - Soft pads and silicone-coated straps to protect paintwork.



- > **MATERIAL** Polypropylene reinforced with glass fibre
- > **WHEEL DIAMETER** 26" / 27.5" / 650B / 28" / 29"
- > **MAXIMUM RECOMMENDED TYRE WIDTH** up to 2.6" / 65 mm
- > **PROTECTION LEVEL** Maximal
- > **MOUNTING**  
MD-Strap - For front Ø 10 to 55 mm and rear Ø 10 to 32 mm.  
Front strap 210 mm / Rear strap 150 mm
- > **WEIGHT** 260 g + 330 g
- > **FRONT MUDGUARD DIMENSIONS (L x w x h)**  
515 x 65 x 200 mm
- > **REAR MUDGUARD DIMENSIONS (L x w x h)**  
710 x 65 x 260 mm

# SHIELD R35 & G50

## // GRAVEL BIKE MUDGUARD SET



**ADJUSTABLE UNIVERSAL MOUNT** - Quick to install and remove.

**ADAPTABLE LENGTH** - 3 mud flaps supplied of 20, 60 and 120 mm.

**FRAME PROTECTION** - Soft pads and silicone-coated straps to protect paintwork.

**DISCREET AND EFFICIENT** - Mudguard positioned close to the wheel.

**UNIVERSEL ROAD** - For 700c / 28" tyres up to 32 mm (R35).

**UNIVERSAL GRAVEL** - For 650B / 28" / 700C tyres up to 48 mm (G50).



Ref. 2545

Ref. 2546



### SHIELD G50

- > **MATERIAL** Technopolymer (PP + 20% FG)
- > **WHEEL DIAMETER**  
650b / 28" / 700c
- > **MAXIMUM RECOMMENDED TYRE WIDTH** 48 mm
- > **PROTECTION LEVEL** Maximal
- > **MOUNTING** MD-Strap. For front Ø 10 to 55 mm and rear Ø 10 to 32 mm. Front 210 mm / rear 150 mm straps length.
- > **WEIGHT** 195 g + 212 g (with mud flap 20 mm)
- > **DIMENSIONS (L x w x H)**  
Front : 461 x 54 x 210 mm - Rear : 560 (with mud flap 20 mm) x 54 x 210 mm

### SHIELD R35

- > **MATERIAL** Technopolymer (PP + 20% FG)
- > **WHEEL DIAMETER**  
700c / 28"
- > **MAXIMUM RECOMMENDED TYRE WIDTH** 32 mm
- > **PROTECTION LEVEL** Maximal
- > **MOUNTING** MD-Strap. For front Ø 10 to 55 mm and rear Ø 10 to 32 mm. Front 210 mm / rear 150 mm straps length.
- > **WEIGHT** 166 g + 177 g (with mud flap 20 mm)
- > **DIMENSIONS (L x w x H)**  
Front : 498 x 34 x 210 mm  
Rear : 572 (with mud flap 20 mm) x 34 x 210 mm



## SHIELD S10

Ref. 2562

// REAR-WHEEL, SADDLE-MOUNTED ROAD BIKE MUDGUARD



+ SHIELD LITE M

Ref. 2560



## SHIELD LITE FRONT

Ref. 2513

// FRONT MUDGUARD FOR GRAVEL



## CROOZER ROAD

Ref. 2375

// FRONT MUDGUARD FOR ROAD BIKES



## SWAN ROAD

Ref. 2470

// REAR MUDGUARD FOR ROAD BIKES



SHIELD S10

SHIELD LITE FRONT

CROOZER ROAD

SWAN ROAD

- > **MATERIAL**  
Polypropylene
- > **WHEEL DIAMETER**  
650B / 700C / 28"
- > **MAX. RECOMMENDED TYRE WIDTH**  
38 mm / 40 mm
- > **PROTECTION LEVEL**  
Minimal
- > **MOUNTING**  
Saddle-rail mounting
- > **WEIGHT** 55 g / 15 g
- > **DIMENSIONS (LxwxH)**  
288 x 85 - 62 x 30 mm  
330 x 100 x 0,7 mm

- > **MATERIAL**  
Polypropylene
- > **WHEEL DIAMETER**  
650B / 700C / 28" / 29"
- > **MAX. RECOMMENDED TYRE WIDTH**  
50 mm
- > **PROTECTION LEVEL**  
Minimal
- > **MOUNTING**  
X6 zip-ties included
- > **WEIGHT** 17 g
- > **DIMENSIONS (LxwxH)**  
164 x 186 mm

- > **MATERIAL**  
Polypropylene and elastomer straps
- > **WHEEL DIAMETER**  
650C / 700C / 28"
- > **MAX. RECOMMENDED TYRE WIDTH**  
40 mm
- > **PROTECTION LEVEL**  
Minimal
- > **MOUNTING**  
X2 Elastic straps (165 mm)
- > **WEIGHT** 60 g
- > **DIMENSIONS (LxwxH)**  
390 x 48 - 70 x 47 mm

- > **MATERIAL**  
Technopolymer
- > **WHEEL DIAMETER**  
650C / 700C / 28"
- > **MAX. RECOMMENDED TYRE WIDTH**  
40 mm
- > **PROTECTION LEVEL**  
Maximal
- > **MOUNTING**  
MD-Turn  
On seat post
- > **WEIGHT** 150 g
- > **DIMENSIONS (LxwxH)**  
640 x 48 x 100 mm



## TRAIL

	TRAIL 65	TRAIL 55	TRAIL 45	TRAIL TEEN 60	TRAIL KID
REF.	2438	2435	2430	2465	2295
MATERIAL	Polypropylene - Steel bracket.				
WHEEL DIAMETER	650B / 27.5" 28" / 29"	26" / 650B 27.5" / 28"	700C / 28"	24" / 26"	20"
MAX. RECOMMENDED TYRE WIDTH	2.4"- 60 mm	2.35"- 50 mm	40 mm	2.2"- 55 mm	1.75"- 45 mm
PROTECTION LEVEL	Maximal				
MOUNTING	<b>Front:</b> Standard-Fix (X2 steel brackets / X1 CHC M5 x 14 screw / X1 CHC M5 x 40 screw / X1 CHC M5 x 60 screw / X2 washers M5 / X2 nuts M5) included. <b>Rear:</b> Standard-Fix + adjustable steel stay (X3 zip-ties / X2 soft sleeves) included.		Standard-Fix (X2 steel brackets / X1 CHC M5 x 14 screw / X1 CHC M5 x 40 screw / X1 CHC M5 x 60 screw / X2 washers M5 / X2 nuts M5 / X1 elastic clamp) included.		
WEIGHT	360 g	205 g	150 g	208 g	185 g
SET DIMENSIONS (L x W x H)	760 x 65 x 150 mm	710 x 55 x 170 mm	680 x 45 x 130 mm	750 x 60 x 185 mm	480 x 50 x 100 mm
FRONT FENDER DIMENSIONS	655 x 65 mm	635 x 55 mm	560 x 45 mm	600 x 60 mm	330 x 50 mm
REAR FENDER DIMENSIONS	760 x 65 mm	770 x 55 mm	680 x 45 mm	750 x 60 mm	480 x 50 mm

## DEFLECTOR FC50

Ref. 2511

### // FRONT MUDGUARD AND FRAME PROTECTION



## DEFLECTOR RC50

Ref. 2516

### // REAR MUDGUARD ON SEAT POST



#### DEFLECTOR FC50

- > **MATERIAL** Polypropylene and elastomer straps
- > **WHEEL DIAMETER** 24" / 26" / 27.5" / 28" / 29"
- > **MAXIMUM RECOMMENDED TYRE WIDTH** 3.0"
- > **PROTECTION LEVEL** Minimal
- > **MOUNTING** X2 Elastic straps (165 mm)
- > **WEIGHT** 62 g
- > **DIMENSIONS (L x W x H)** 340 x 80 - 60 x 35 mm
- > **AVAILABLE IN SET** Deflector RC50 (set : #2518)

#### DEFLECTOR RC50

- > **MATERIAL** Polypropylene
- > **WHEEL DIAMETER** 26" / 650B / 700C / 28"
- > **MAXIMUM RECOMMENDED TYRE WIDTH** 1.75"- 45 mm
- > **PROTECTION LEVEL** High
- > **MOUNTING** MD-Turn - On seat post
- > **WEIGHT** 115 g
- > **DIMENSIONS (L x W x H)** 570 x 47-55 x 140 mm
- > **AVAILABLE IN SET** Deflector FC50 (set: #2518)

## SKIN ARMOR 3 & 15 METERS ROLL

### // INVISIBLE PROTECTION FOR BICYCLE FRAME

The Skin Armor roll is a transparent flexible polyurethane protective film specifically developed for frames and components. It protects your bike from scratches and rubbing.

The Glue Shield technology requires no liquids, so it's quick and easy to apply.

This roll format allows you to cut patches of different shapes and lengths to suit your needs, offering customised protection for your components and your bike.

The Skin Armor is resistant to water (high-pressure washing), tearing, perforation, peeling, UV rays and temperature variations. It's the ideal solution for cyclists looking for an effective, discreet solution to preserve their bike's appearance and resale value.



**HIGH RESISTANCE** - No rips. Excellent resistance to puncture and peeling.

**UV RESIST** - Does not change colour with time.

**WASHABLE** - Resistant to high-pressure water jets.

**TEMPERATURE FLUCTUATIONS RESIST** - From -30°C to +100°C / From -22°F to +212°F.

**GLUE SHIELD TECHNOLOGY** - Quick and easy dry fitting. High adhesive strength.



#### SKIN ARMOR 3 METERS ROLL

- > **FINISH**  
Shiny (ref.2609)  
Matt (ref. 2624)
- > **FOR** Frame and fork
- > **MATERIAL**  
Polyurethane
- > **THICKNESS**  
250 microns
- > **COLOUR**  
Clear
- > **WIDTH** 58 mm
- > **LENGTH** 3 m
- > **DIMENSIONS (L x w x H)**  
58 x 58 x 58 mm

#### SKIN ARMOR 15 METERS ROLL

- > **FINISH**  
Shiny (ref.2604)  
Matt (ref.2617)
- > **FOR** Frame and fork
- > **MATERIAL**  
Polyurethane
- > **THICKNESS**  
250 microns
- > **COLOUR**  
Clear
- > **WIDTH** 58 mm
- > **LENGTH** 15 m
- > **DIMENSIONS (L x w x H)**  
162 x 150 x 62 mm

# SKIN ARMOR

## // INVISIBLE PROTECTION KIT FOR BICYCLE FRAME



**HIGH RESISTANCE** - No rips. Excellent resistance to puncture and peeling.

**UV RESIST** - Does not change colour with time.

**WASHABLE** - Resistant to high-pressure water jets.

**TEMPERATURE FLUCTUATIONS RESIST** - From -30°C to +100°C / From -22°F to +212°F.

**GLUE SHIELD TECHNOLOGY** - Quick and easy dry fitting. High adhesive strength.

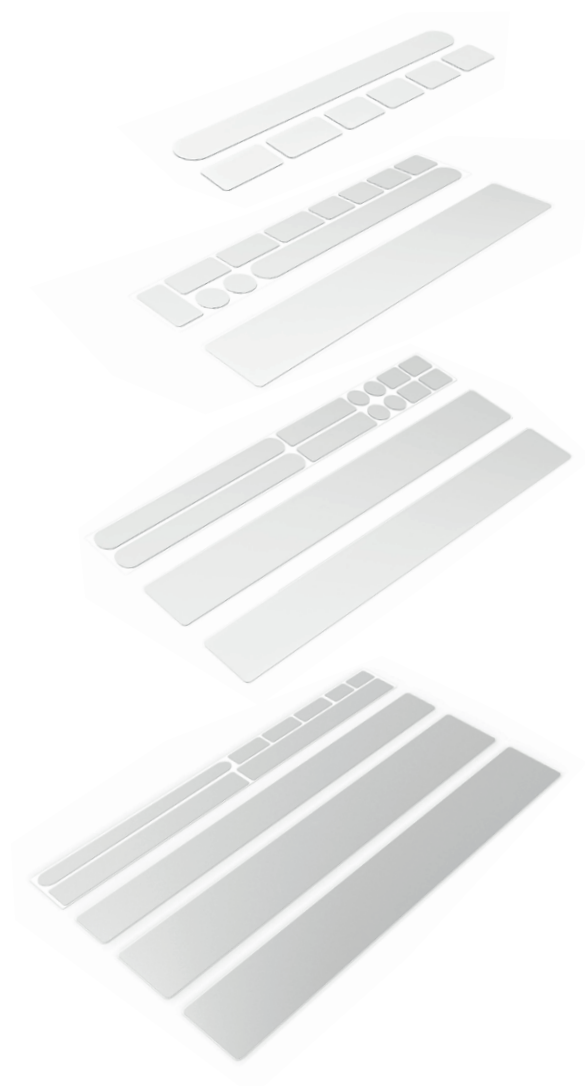

	SKIN ARMOR S	SKIN ARMOR M	SKIN ARMOR L	SKIN ARMOR XL
<b>FOR</b>	Gloss and matt finish frame and parts			
<b>MATERIAL</b>	Polyurethane			
<b>THICKNESS</b>	250 microns			
<b>COLOUR</b>	Clear			
<b>FINISH</b>	Shiny (ref.2603)	Shiny (ref.2600)	Shiny (ref.2601) Matt (ref.2607)	Shiny (ref.2618) Matt (ref.2619)
<b>INCLUDED</b>	<ul style="list-style-type: none"> <li>• 1 chainstay protection 252 x 25 mm</li> <li>• 4 patches 35 X 25 mm</li> <li>• 2 patches 25 x 45 mm</li> </ul>	<ul style="list-style-type: none"> <li>• 1 down-tube protection 345 X 58 mm</li> <li>• 1 rear base-protection 252 X 25 mm</li> <li>• 4 patches 35 X 25 mm</li> <li>• 4 patches 50 X 25 mm</li> <li>• 2 patches Ø 25 mm</li> </ul>	<ul style="list-style-type: none"> <li>• 1 down-tube protection 500 X 58 mm</li> <li>• 1 top-tube protection 500 X 58 mm</li> <li>• 2 rear base-protection 252 X 25 mm</li> <li>• 2 crank protection 105 X 25mm</li> <li>• 4 patches 35 X 25 mm</li> <li>• 4 patches Ø 25 mm</li> </ul>	<ul style="list-style-type: none"> <li>• 2 down-tube protection 500 X 90 mm</li> <li>• 1 top-tube protection 500 X 58 mm</li> <li>• 2 seat stay protection 244 X 35 mm</li> <li>• 1 rear base-protection 252 X 25 mm</li> <li>• 3 patches 50 X 25 mm</li> <li>• 2 patches 35 x 25 mm</li> </ul>
<b>DIMENSIONS (L x w x h)</b>	290 x 74 x 2 mm	395 x 139 x 3 mm	548 x 135 x 3 mm	548 x 174 x 3 mm

## CS ARMOR

Ref. 2605

### // HIGH-RESISTANCE CHAINSTAY PROTECTION

- +** **BETTER PROTECTION** - Thickness 1,8 mm.
- UNIVERSAL MOUNTING** - Compatible with all frames.
- WASHABLE** - With low-pressure jet.
- GLUE SHIELD TECHNOLOGY** - High-resistance adhesive. Doesn't damage paint or varnish.
- NOISE CANCELLING** - Flexible material for good impact absorption.



## DT ARMOR

Ref. 2522

### // DOWN TUBE PROTECTION

- +** **BETTER PROTECTION** - Thickness 1.8 mm.
- UNIVERSAL MOUNTING** - Compatible with all frames.
- WASHABLE** - With low-pressure jet.
- GLUE SHIELD TECHNOLOGY** - High-resistance adhesive. Doesn't damage paint or varnish.
- NOISE CANCELLING** - Flexible material for good impact absorption.

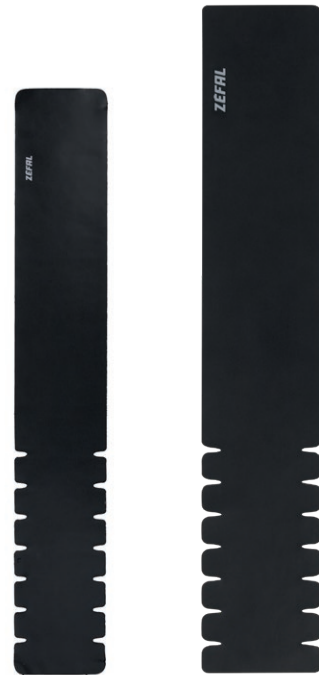

## DT ARMOR XL

Ref. 2523

### // EXTRA LARGE DOWN TUBE PROTECTION



#### CS ARMOR

- > **FOR** Chain Stay
- > **MATERIAL** Polyurethane
- > **THICKNESS** 1,8 mm
- > **COLOUR** Black
- > **FINITION** Matt
- > **WEIGHT** 12 g
- > **DIMENSIONS (L x w x H)** 250 x 33 x 1,8 mm

#### DT ARMOR

- > **FOR** Down tube frame
- > **MATERIAL** Polyurethane
- > **THICKNESS** 1,8 mm
- > **COLOUR** Black
- > **FINITION** Matt
- > **WEIGHT** 48 g
- > **DIMENSIONS (L x w x H)** 450 x 70 x 1.8 mm

#### DT ARMOR XL

- > **FOR** Down tube frame
- > **MATERIAL** Polyurethane
- > **THICKNESS** 1,8 mm
- > **COLOUR** Black
- > **FINITION** Matt
- > **WEIGHT** 72 g
- > **DIMENSIONS (L x w x H)** 500 x 90 x 1.8 mm

# CRANK ARMOR

Ref. 2630 - 2637

## // CRANKS PROTECTION

- +** **IMPACT RESISTANT** - Durability and high resistance.
- QUICK MOUNTING** - Easy mounting on the crank.
- E-BIKE FRIENDLY** - For E-Bike cranks, in aluminum or carbon.

## + CRANK ARMOR XL

Ref. 2620



SRAM.	CRANK ARMOR	CRANK ARMOR XL
XX1		✓
X01		✓
XX		✓
X0		✓
X1	✓	
GX	✓	
NX	✓	
X9	✓	
X7	✓	
X5	✓	
RED		✓
FORCE		✓
RIVAL	✓	
APEX	✓	
RIVAL XPLR	✓	
APEX XPLR	✓	
RED AXS		✓
FORCE AXS		✓
GX EAGLE (FC-GX-1002-A1, FC-GX-D1)	✓	
XO EAGLE (FC-X0-D1)	✓	

SHIMANO	CRANK ARMOR	CRANK ARMOR XL
XTR (9200 - M9100 - 9120 - 9130)		✓
DEORE XT		✓
SLX (M7000 - 7100 - 7120)	✓	
DEORE		✓
ALIVIO	✓	
ACERA	✓	
DURA ACE (R9000 - R9100 - R9200)	✓	
ULTEGRA (R8000 - R8100 - R8200)	✓	
105 (R7000 - R7100 - R7200) (= / < 2022)	✓	
TIAGRA	✓	
SORA		✓
E8000	✓	
GRX600	✓	
GRX810	✓	
105 (2022)		✓
ZEE (FC-M640 / FC-M645)	✓	
DEORE XT FC-M8100	✓	
DEORE FC-M6100	✓	
FC-E8000	✓	



### CRANK ARMOR

- > **FOR** Crank
- > **MATERIAL** Soft Thermoplastic
- > **COLOURS** Black (2637) / Grey (2636) / Red (2632) / Green (2635) / Cyan Blue (2634) / Orange (2631) / Fluorescent Yellow (2630) / Pink (2633)
- > **WEIGHT** 18 g
- > **DIMENSIONS (L x w x H)** 57 x 39 x 17 mm

### CRANK ARMOR XL

- > **FOR** Crank
- > **MATERIAL** Soft Thermoplastic
- > **COLOURS** Black
- > **WEIGHT** 18 g
- > **DIMENSIONS (L x w x H)** 52 x 42.5 x 17.5 mm



**// TRANSPORT**

## Z ADVENTURE F1

Ref. 7039

### // MINIMALIST HANDLEBAR BAG

The lightweight, practical Z Adventure F1, with a capacity of 1.2 litres, is ideal for carrying all your essentials when you're out and about on your bike, while preserving its lines. This bag is roomy enough to hold a phone, wallet, keys, multitool and even a mini-pump. It has pockets and compartments for easy organisation. You won't need to overload your jersey pockets.

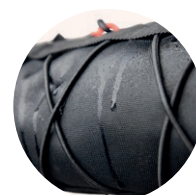

**COMPACT** - Adaptable to any handlebar width.

**LIGHT** - Durable and lightweight material.

**STABILITY** - Anti-rotation system.

**COLOURED LINING** - The red interior enhances contrast, making it easier to find your things.

**UNIVERSAL MOUNTING** - Using self-gripping straps.

## Z ADVENTURE F2

Ref. 7089

### // COMPACT, WATERPROOF HANDLEBAR BAG



**WATERPROOF** - IPX4, welded bag with waterproof material.

**COMPACT** - Adaptable to any handlebar width.

**UNIVERSAL MOUNTING** - Using self-gripping straps.

**STABILITY** - Anti-rotation system.

**LIGHT** - Durable and lightweight material



#### Z ADVENTURE F1

- > **TYPE** Handlebar bag
- > **MATERIAL** Polyester TPU 420 D
- > **DIMENSIONS (L x w x H)**  
200 mm x 90 mm x 90 mm
- > **WEIGHT** 130 g
- > **MOUNTING** Self-gripping straps
- > **CAPACITY** 1.2 L
- > **CLOSING** Water repellent zip
- > **MAXIMUM LOAD** 2 kg

#### Z ADVENTURE F2

- > **TYPE** Handlebar bag
- > **MATERIAL** Polyester TPU 600 D
- > **DIMENSIONS (L x w x H)**  
250 mm x 120 mm x 120 mm
- > **WEIGHT** 135 g
- > **MOUNTING** Self-gripping straps
- > **CAPACITY** 2.5 L
- > **CLOSING** Water repellent zip

## Z ADVENTURE FORK PACK

Ref. 7051

### // WATERPROOF BAG AND UNIVERSAL FORK HOLDER

- +** **WATERPROOF** - Welded bag with waterproof material and roll top closure.
- UNIVERSAL** - Compatible with rigid and suspension forks (Ø16 to 36mm), with or without threaded studs.
- ADJUSTABLE HEIGHT** - Thanks to the 4 fixing holes.
- STABILITY** - Bag secured by two self-gripping straps.
- VISIBILITY** - Reflective side strips for better visibility at night.



## Z ADVENTURE DRY BAG 4L & 6L

### // WATERPROOF BAG FOR BIKEPACKING

- +** **WATERPROOF** - Welded bag with waterproof material and roll top closure.
- STABILITY** - Bag secured by two self-gripping straps.
- VISIBILITY** - Reflective side strips for better visibility at night.
- UNIVERSAL** - Fits all bikepacking cages.



Ref. 7032

Ref. 7033



#### Z ADVENTURE FORK PACK

- > **TYPE** Bikepacking fork bags
- > **MATERIAL** Holder in Fiber reinforced Polypropylene. Bag in Polyester 420D TPU
- > **DIMENSIONS** Ø150 x 365 mm
- > **WEIGHT** 346 g (including 204 g for the bag)
- > **MOUNTING** Clip loop and screws or Gizmo
- > **CAPACITY** 6 L
- > **CLOSING**  
By roll top and clip loop
- > **MAXIMUM LOAD** 2.5 kg

#### Z ADVENTURE DRY BAG 4L & 6L

- > **TYPE** Bikepacking fork bags
- > **MATERIAL**  
Polyester 420D TPU
- > **DIMENSIONS**  
4L : Ø130 x 285 mm  
6L : Ø150 x 365 mm
- > **WEIGHT** 160 g / 205 g
- > **MOUNTING** Clip loop
- > **CAPACITY** 4 L / 6 L
- > **CLOSING**  
By roll top and clip loop
- > **MAXIMUM LOAD** 2.5 kg



## Z ADVENTURE F5

Ref. 7017

### // WATERPROOF HANDLEBAR BAG WITH MEDIUM VOLUME

This universal handlebar bag is ideal for carrying light, large-sized items, such as a sleeping bag or a floor mat, in a way that evenly distributes the weight on the bicycle. With a capacity of 5 litres, this perfectly waterproof bag is easy to install and remove thanks to its hook-and-loop straps. Its compact size makes it particularly suitable for small frames. Equipped with reflective strips and an attachment loop for lights, the Z Adventure F5 can safely adapt to fit all types of handlebars.



- +** **WATERPROOF** - Heat-sealed waterproof material.
- MEDIUM CAPACITY** - Large carrying volume.
- DURABLE** - Durable material. Reinforced straps and mount.
- UNIVERSAL** - Adjustable and durable self-adhesive straps. Two mounting positions: 45 to 65mm spacing and 190 to 210mm spacing.



## Z ADVENTURE F10

Ref. 7000

### // WATERPROOF HANDLEBAR BAG WITH LARGE VOLUME

- +** **LARGE CAPACITY** - Very large carrying volume.



## Z ADVENTURE F5

- > **TYPE** Handlebar bag
- > **MATERIAL** PU 210 D
- > **DIMENSIONS** 380 x 150 x 150 mm
- > **WEIGHT** 320 g
- > **MOUNTING** Self-gripping straps
- > **CAPACITY** 5 L
- > **CLOSING**  
Roll top
- > **MAXIMUM LOAD** 4 kg

## Z ADVENTURE F10

- > **TYPE** Handlebar bag
- > **MATERIAL** PU 210 D
- > **DIMENSIONS** 400 x 180 x 180 mm
- > **WEIGHT** 340 g
- > **MOUNTING** Self-gripping straps
- > **CAPACITY** 10 L
- > **CLOSING**  
Roll top
- > **MAXIMUM LOAD** 4 kg

## Z ADVENTURE AERO F12 & F8

Ref. 7087 - 7088

### // WATERPROOF BAG FOR AEROBARS

- +** **WATERPROOF** - Welded bag with waterproof material and roll top closure.
- WIDE OPENING** - Quick access from the front.
- QUICK MOUNTING / DISMOUNTING** - Fastening with hook and loop straps.
- DURABLE** - Tear-resistant material.
- LIGHTNESS** - Simple construction with integrated mounting.



## Z ADVENTURE POUCH BAG

Ref. 7090

### // HANDLEBAR POUCH BAG FOR WATER BOTTLE AND ACCESSORIES

- +** **UNIVERSAL** - Compatible with all types of handlebars.
- EASY ACCESS** - One-handed opening and closing.
- MODULAR** - Can be mounted on the right or left side thanks to the removable straps.
- STABILITY** - 3 fixing points for increased stability under heavy loads.
- VISIBILITY** - Reflective strips for better visibility at night.



## HANDLEBAR BAG 7L

Ref. 7003

### // 7L BIKE FRONT BAG

- +** **WATERPROOF** - Water-resistant material and zip. Rain-cover.
- LARGE LOAD VOLUME** - Load volume of 7L. Ideal for touring.
- CLEAR WINDOW** - Possibility of inserting a map, a tablet or a phone.
- UNIVERSAL MOUNTING** - Compatible with all types of handlebars (25,4 mm - 31,8 mm), including the ones with e-Bike Console.
- Z-FRONT** - Clip-on mounting with bag locking and unlocking system.



F8 / F12

- > **TYPE** Handlebar bag
- > **MATERIAL** Polyester 420D TPU
- > **DIMENSIONS**  
F8 : 410 mm x 165 mm x 165 mm  
F12 : 410 mm x 200 mm x 200 mm
- > **WEIGHT** 217 g / 260 g
- > **MOUNTING**  
Self-gripping straps
- > **CAPACITY** 8 L / 12 L
- > **CLOSING** Roll top
- > **MAXIMUM LOAD** 3.5 kg

POUCH BAG

- > **TYPE** Stem bag
- > **MATERIAL**  
Polyester 420D TPU
- > **DIMENSIONS**  
180 mm x 90 mm x 90 mm
- > **WEIGHT** 80 g
- > **MOUNTING**  
Self gripping straps
- > **CAPACITY** 1.1 L
- > **CLOSING** With double elastic drawstring

HANDLEBAR BAG

- > **MATERIAL** Polyester 420D TPU
- > **DIMENSIONS**  
230 x 180 x 175 mm
- > **WEIGHT** 860 g
- > **MOUNTING** Z-Front
- > **CAPACITY** 7 L
- > **ZIP** Water repellent zip

# Z ADVENTURE T1

Ref. 7015

## // TOP-TUBE BAG

The Z Adventure T1 is a horizontal tube bag that lets you carry your most essential items (wallet, nutrition, phone, repairs, powerbank) on your bike. Thanks to its 100% welded construction and waterproof zip, your gear is protected from the elements while remaining quickly accessible. This universal bag can be mounted on a road, gravel or mountain bike, making it a versatile choice for all types of bike rides.

To keep your belongings organised, the bag has a key hook and an internal mesh pocket. What's more, it has an integrated cable channel in the centre of the bag, allowing you to run a USB charging cable (for a GPS or other device) while maintaining a sleek, stylish look.

With dimensions designed to maximise carrying volume while minimising the risk of touching the bag with your knees while riding, the Z Adventure T1 is the ideal choice for cyclists looking to carry their gear without compromising comfort or the handling of their bike.



- +** **CABLE ACCESS** - Allowing the rider to charge their GPS, phone, lights...
- WATERPROOF** - Welded bag and waterproof zip.
- UNIVERSAL MOUNTING** - Using self gripping straps.
- STORAGE** - Internal mesh pocket and key hook.
- LIGHTWEIGHT** - Lightweight, resistant material.

## + Z ADVENTURE T1 BOLT Ref. 7016

This «bolt on» bag is compatible with road and gravel bikes fitted with threaded holes on the top horizontal tube, as long as these holes face upwards. By eliminating the risk of abrasion from rubbing straps, this bag protects your bike's paintwork and frame. The Z Adventure T1 Bolt is easily fitted to your bike using the screws supplied.



### ⚙️ Z ADVENTURE T1 Z ADVENTURE T1 BOLT

- > **TYPE** Top-tube frame bags
- > **MATERIAL** Polyester 420D TPU
- > **DIMENSIONS** 220 mm x 50 mm x 100 mm
- > **WEIGHT** 150 g
- > **MOUNTING** Self gripping straps
- > **CAPACITY** 1 L
- > **CLOSING**  
Waterproof zip
- > **MAXIMUM LOAD** 1kg

- > **TYPE** Top-tube frame bags
- > **MATERIAL** Polyester 420D TPU
- > **DIMENSIONS** 220 mm x 50 mm x 100 mm
- > **WEIGHT** 150 g
- > **MOUNTING** M5 x 16 mm screws (included)
- > **CAPACITY** 1 L
- > **CLOSING**  
Waterproof zip
- > **MAXIMUM LOAD** 1kg

## Z ADVENTURE T3

Ref. 7091

### // TOP-TUBE BAG

- +** **WATERPROOF** - Welded bag with waterproof material.
- STORAGE** - Inside zipped pocket.
- UNIVERSAL MOUNTING** - Using self gripping straps.
- ANTI-SLIP MATERIAL ON THE LOWER PART** - Better grip to the top tube.
- LIGHTWEIGHT** - Lightweight, resistant material.



## Z AERO

Ref. 7006

### // AERODYNAMIC BAG FOR NUTRITION

- +** **WATER REPELLENT** - Water-resistant material and zip.
- UNIVERSAL FITTING** - Using self gripping straps or screws.
- REMOVABLE FRONT STRAP** - Several possible settings.
- LIGHTWEIGHT** - Lightweight, resistant material.
- COMPARTMENTS** - Easy storage.



#### Z ADVENTURE T3

- > **TYPE** Top-tube frame bags
- > **MATERIAL** Polyester 420D TPU
- > **DIMENSIONS**  
440 x 45 x 100 mm
- > **WEIGHT** 215 g
- > **MOUNTING** Self gripping straps
- > **CAPACITY** 2 L
- > **CLOSING** Water repellent zip

#### Z AERO

- > **TYPE** Top-tube frame bags
- > **MATERIAL** Polyester 420D TPU
- > **DIMENSIONS**  
220 x 65 x 45 mm
- > **WEIGHT** 95 g
- > **MOUNTING** Universal with self gripping straps or with screws
- > **CAPACITY** 0.4 L
- > **CLOSING** Water repellent zip

# Z ADVENTURE C2, C3 & C4

## // WATERPROOF FRAME BAG

These waterproof (IPX4) frame bags have been designed to accompany all cycling adventurers, whether on road, gravel, mountain or touring bikes. Available in 3 sizes, the Z Adventure C2, C3 and C4 can be mounted on all bikes thanks to the removable and adjustable straps.

The volumes are sufficient to carry a jacket in addition to a repair kit, a phone, a battery, a pair of gloves... The size should be chosen according to your needs but also according to the space inside your frame.



- +** **UNIVERSAL MOUNTING** - Using self-gripping straps.
- WATERPROOF** - IPX4, welded bag with waterproof material.
- WIDE OPENING** - Better access to the content.
- STORAGE** - Inside zipped pocket.
- LIGHT** - Durable and lightweight material.

Ref. 7092 - 7093 -7094

## C2 C3 C4

- > **TYPE**  
Frame bags
- > **MATERIAL**  
Polyester 600D TPU
- > **DIMENSIONS**  
340 x 110 x 65 mm
- > **WEIGHT**  
155 g
- > **MOUNTING**  
Self-gripping straps
- > **CAPACITY**  
2.5 L
- > **CLOSING**  
Water repellent zip

- > **TYPE**  
Frame bags
- > **MATERIAL**  
Polyester 600D TPU
- > **DIMENSIONS**  
430 x 115 x 65 mm
- > **WEIGHT**  
210 g
- > **MOUNTING**  
Self-gripping straps
- > **CAPACITY**  
3.3 L
- > **CLOSING**  
Water repellent zip

- > **TYPE**  
Frame bags
- > **MATERIAL**  
Polyester 600D TPU
- > **DIMENSIONS**  
500 x 140 x 65 mm
- > **WEIGHT**  
238 g
- > **MOUNTING**  
Self-gripping straps
- > **CAPACITY**  
4.2 L
- > **CLOSING**  
Water repellent zip

## CONSOLE PACK T1

Ref. 7010

### // TOP-TUBE BAG WITH AN INTEGRATED COMPARTMENT FOR SMARTPHONES



**2 IN 1 SOLUTION** - Smartphone holder and front bag.

**PHONE USE** - Ideal compartment for smartphones, touch screen.

**WATERPROOF** - Water-resistant material and zip. Translucent rain-cover.

**ANTI-SLIP MATERIAL ON THE LOWER PART** - Better grip to the top tube.

**UNIVERSAL MOUNTING** - An extra strap is provided for wide frames.



## CONSOLE PACK T2

Ref. 7011



## CONSOLE PACK T3

Ref. 7012



#### CONSOLE PACK T1

- > **TYPE** Top-tube frame bags
- > **MATERIAL** Polyester 420D TPU
- > **DIMENSIONS**  
185 x 90 x 95 mm
- > **WEIGHT** 175 g
- > **MOUNTING**  
Self gripping straps
- > **CAPACITY** 0.8 L / 49 c.i.
- > **CLOSING** Water repellent zip
- > **MAXIMUM PHONE SIZE**  
160 x 80 mm

#### CONSOLE PACK T2

- > **TYPE** Top-tube frame bags
- > **MATERIAL** Polyester 420D TPU
- > **DIMENSIONS**  
205 x 95 x 110 mm
- > **WEIGHT** 200 g
- > **MOUNTING**  
Self gripping straps
- > **CAPACITY** 1.3 L / 79 c.i.
- > **CLOSING** Water repellent zip
- > **MAXIMUM PHONE SIZE**  
175 x 85 mm

#### CONSOLE PACK T3

- > **TYPE** Top-tube frame bags
- > **MATERIAL** Polyester 420D TPU
- > **DIMENSIONS**  
350 x 95 x 110 mm
- > **WEIGHT** 260 g
- > **MOUNTING**  
Self gripping straps
- > **CAPACITY** 1.8 L / 110 c.i.
- > **CLOSING** Water repellent zip
- > **MAXIMUM PHONE SIZE**  
175 x 80 mm

## Z BOX S, M & L

Ref. 7086, 7080 & 7081

### // TOOL BOX

- +** **WATERPROOF** - To protect the content and prevent damage.
- CONVENIENT STORAGE** - Compact and practical.
- UNIVERSAL** - Fits all bottle cages.



## UNIVERSAL TUBE STRAP

Ref. 1035

### // UNIVERSAL TUBE STRAP

- +** **FRAME STRAP** - Extra wide and made from TPU, a resistant material which won't cause damage.
- INNER TUBE STRAP** - Coated in silicone creating a secure hold without causing damage.
- UNIVERSAL** - For all types of bike inner tubes, even the wider ones.
- TYRE LEVERS** - Supplied with 2 highly resistant tyre Z-levers.



## Z FRAME PACK

Ref. 7049

### // FRAME BAG

- +** **LIGHTWEIGHT, RESISTANT MATERIAL** - Made from a high-resistance material.
- UNIVERSAL MOUNTING** - For all types of bikes. Quick and easy to fit.
- LARGE VOLUME** - The Z Frame pack has a volume of 1.3L, two mesh pockets, key chain and straps for a mini-pump.
- WIDE OPENING** - Better access to the content.
- REFLECTIVE STRIPES** - Better visibility of the bike.



#### Z BOX S, M & L

- > **TYPE** Box
- > **MATERIAL** Polypropylene
- > **DIMENSIONS**  
S : 140 mm x 75 mm x 75mm  
M : 170 mm x 75 mm x 75mm  
L : 240 mm x 75 mm x 75mm
- > **WEIGHT** 65g, 80g & 130g
- > **MOUNTING** Bottle cage
- > **CAPACITY** 0.5L, 0.6L & 0.8L
- > **CLOSING** Screw cap

#### UNIVERSAL TUBE STRAP

- > **TYPE** Universal Strap
- > **MATERIAL** TPU and Nylon with silicone
- > **DIMENSIONS** 420 x 40 mm
- > **WEIGHT** 29 g
- > **MOUNTING** Self gripping strap

#### Z FRAME PACK

- > **TYPE** Frame bag
- > **MATERIAL** Polyester 420 D Ripstop
- > **DIMENSIONS** 270 x 100 x 80 mm
- > **WEIGHT** 125 g
- > **MOUNTING** Self gripping straps
- > **VOLUME** 1,3L / 61 c.i
- > **CLOSING** Water repellent zip





# Z ROAD PACK

Ref. 7013

NEW

## // COMPACT, ORGANISED SADDLE BAGS FOR YOUR REPAIR KIT

The Z ROAD PACK and Z OFF-ROAD PACK are designed to hold a modern bike inner tube and all the essential tools for quick repairs. It holds an inner tube, a multitool, a CO2 cartridge, an inflator and two tyre levers, all neatly organised in a space divided in two by a spacer. The interior compartments are designed to protect the inner tube from abrasion and provide easy access to tools. 100% waterproof, the contents remain protected from the elements, whatever the weather.

The bags attach easily to the underside of your bike saddle thanks to a wide hook-and-loop strap, which can be removed if you want to strap it onto another bag. They have been designed as your bike's first aid kit, to be used in the event of repairs. You won't need to access it every time you ride.

You can ride with confidence, knowing that your tools are close at hand if you need them. The ideal choice for cyclists looking to combine convenience and style on the road.



**WATERPROOF** - Welded bag and waterproof zip.

**MINIMALIST SADDLE BAG** - To carry all your repair essentials.

**UNIVERSAL MOUNTING** - Quick mounting for all standard saddle rails.

**COMPARTMENTS** - Protects the inner tube from abrasive objects in the bag.

**MEDIUM CAPACITY** - Provides enough room for 1 tube (=700x23-32) + 2 tyre levers + 1 multi-tool + 16g cartridge + a CO2 inflator as the Zéfal EZ Big Shot.

## + Z OFF-ROAD PACK

Ref. 7014

**MEDIUM CAPACITY** - Provides enough room for 1 tube (=29X1.9"-2.5") + 2 tyre levers + 1 multi-tool + 25g cartridge + a CO2 inflator as the Zéfal EZ Big Shot.



### Z ROAD PACK

- > **TYPE** Saddle bags
- > **MATERIAL** Polyester 420D TPU/PU
- > **DIMENSIONS**  
120 x 80 x 35 mm
- > **WEIGHT** 85g
- > **MOUNTING** Self gripping straps  
(325 mm x 38 mm)
- > **CAPACITY** 0.35 L
- > **CLOSING** Waterproof zip
- > **MAXIMUM LOAD** 1 kg

### Z OFF-ROAD PACK

- > **TYPE** Saddle bags
- > **MATERIAL** Polyester 420D TPU/PU
- > **DIMENSIONS**  
120 x 80 x 60 mm
- > **WEIGHT** 90 g
- > **MOUNTING** Self gripping straps (370 mm x 38 mm)
- > **CAPACITY** 0.60 L
- > **CLOSING** Waterproof zip
- > **MAXIMUM LOAD** 1 kg

## Z LIGHT PACK

### // SADDLE BAG

- +** **ULTRA LIGHT BAG** - Ideal for road cyclists and triathletes.
- FOR ALL TYPE OF BIKE** - Quick mounting.
- REFLECTIVES STRIPES** - Better visibility of the bike.
- LIGHT MOUNT** - Increase the security at night.

Ref. 7042 → 7045



## IRON PACK 2DS

### // AERODYNAMIC SADDLE BAG

- +** **HIGHLY RESISTANT BAG** - Strong structure with material reinforcements.
- WIDE OPENING** - Better access to the content.
- LIGHT MOUNT** - Increase the security at night.
- WATER REPELLENT** - Water-resistant material and zip.
- MESH POCKET** - Integral and quick to access.

Ref. 7026 - 7027



#### Z LIGHT PACK

- > **TYPE** Saddle bags
- > **MATERIAL** Polyester 420 D Ripstop
- > **DIMENSIONS**  
 XS : 130 x 60 x 60 mm  
 S : 140 x 70 x 65 mm  
 M : 180 x 95 x 70 mm  
 L : 220 x 95 x 90 mm
- > **WEIGHT** 34 g, 58 g, 95 g, 105 g
- > **MOUNTING** Self gripping straps
- > **CAPACITY**  
 XS : 0,3 L / 18 c.i  
 S : 0,5 L / 28 c.i  
 M : 0,9 L / 54 c.i  
 L : 1,4 L / 83 c.i
- > **CLOSING** Water repellent zip

#### IRON PACK 2 DS

- > **TYPE** Saddle bags
- > **MATERIAL** Polyester 420D TPU
- > **DIMENSIONS**  
 S : 160 x 70 x 75 mm  
 M : 175 x 90 x 95 mm
- > **WEIGHT** 100 g / 135 g
- > **MOUNTING** Double self gripping straps
- > **CAPACITY** 0,5L / 0,9L
- > **CLOSING** Water repellent zip

## Z ADVENTURE R5

Ref. 7005

### // WATERPROOF 5L SADDLE BAG



- WATERPROOF** - Heat-sealed waterproof material.
- LARGE LOAD VOLUME** - Load volume of 5L. Ideal for long outings.
- DURABLE** - Reinforced material at the mounting points to avoid rubbing and the risk of tearing.
- UNIVERSAL** - Adjustable and durable self-adhesive straps.
- EXTERNAL STRAPS** - For the quick attaching and storing of additional items.



## Z ADVENTURE R11 & R17

Ref. 7001 &amp; 7002

### // WATERPROOF SADDLE BAG WITH LARGE VOLUME



- WATERPROOF** - Heat-sealed waterproof material.
- LARGE LOAD VOLUME** - Adjustable from 5 to 11 L.
- SUSTAINABLE** - Reinforced material at the mounting points to avoid rubbing and the risk of tearing.
- UNIVERSAL** - Adjustable and durable self-adhesive straps.
- ELASTIC CORD** - For the quick attaching and storing of additional items.



#### Z ADVENTURE R5

- > **TYPE** Saddle bags
- > **MATERIAL** Polyester 420D + TPU + Hypalon
- > **DIMENSIONS** 370 x 70-175 x 130 mm
- > **WEIGHT** 400 g
- > **MOUNTING** Self gripping straps
- > **CAPACITY** 5 L
- > **CLOSING** Roll top
- > **MAXIMUM LOAD** 3 kg

#### Z ADVENTURE R11

- > **TYPE** Saddle bags
- > **MATERIAL** TPU 420D (+ Polyester 640D + Hypalon)
- > **DIMENSIONS** 560 x 150 x 170 mm / 22 x 5.9 x 6.7"
- > **WEIGHT** 525 g
- > **MOUNTING** Self gripping straps
- > **VOLUME** 11 L
- > **FERMETURE** Roll top
- > **MAXIMUM LOAD** 5 kg

#### Z ADVENTURE R17

- > **TYPE** Saddle bags
- > **MATERIAL** TPU 420D (+ Polyester 640D + Hypalon)
- > **DIMENSIONS** 620 x 240 x 200 mm / 24.4 x 9.4 x 7.9"
- > **WEIGHT** 675 g
- > **MOUNTING** Self gripping straps
- > **VOLUME** 17 L
- > **CLOSING** Roll top
- > **MAXIMUM LOAD** 5 kg

# Z TRAVELER S20 & S30

Ref. 7100 - 7101

## // BIKE PANNIERS

The Z TRAVELER S20 and Z TRAVELER S30 are a universal, waterproof bike panniers. IPX4 certified, they have been designed to accompany touring cyclists and bike commuters looking to carry large volumes.

their large 20 or 30-litre capacity and hard-wearing 600D polyester construction will give you peace of mind on your daily commute or on longer bike adventures. Functional and practical, these panniers features the universal Z Quick Mount system. It's quick to mount and remove, while the 2 lower hooks ensure stability. Its inside pocket provides quick access to essentials such as keys and wallet.



**QUICK MOUNT SYSTEM** - Panniers can be fitted and removed quickly, and double bottom hooks provide extra support.

**WATERPROOF** - The contents of the pannier stay dry thanks to IPX4 certification.

**UNIVERSAL** - Designed to fit most bike racks.

**RESISTANCE** - Its 600D polyester construction and reinforcements make it highly resistant to impact and abrasion.

**LARGE VOLUME** - For carrying clothes, hygiene products, camping gear or travel accessories.



S20

- > **MATERIAL** Welded 600D polyester + internal TPU coating
- > **DIMENSIONS** 330 x 160 x 380 mm
- > **WEIGHT** 995 g
- > **MOUNTING** Z Quick Mount for tubes Ø 8 to 16 mm
- > **VOLUME** 20 L
- > **CLOSURE** Velcro® + clip
- > **WATERPROOFING** IPX4

S30

- > **MATERIAL** Welded 600D polyester + internal TPU coating
- > **DIMENSIONS** 340 x 210 x 430 mm
- > **WEIGHT** 1100 g
- > **MOUNTING** Z Quick Mount for tubes Ø 8 to 16 mm
- > **VOLUME** 30 L
- > **CLOSURE** Velcro® + clip
- > **WATERPROOFING** IPX4

## URBAN MESSENGER BAG

Ref. 7058

### // BIKE SHOULDER BAG



**ECOLOGICAL AND SUSTAINABLE MATERIAL** - RPET, recycled from plastic bottles.

**CONVERTIBLE INTO A BICYCLE RACK BAG** - Universal attachment for transport on rear rack.

**PRACTICAL** - Inside: one main compartment, one small pocket and straps for a water bottle. Outside: a small pocket and a shoulder strap storage system.

**WATERPROOF** - Rain cover included with practical storage underneath the bag.

**MINIMALIST AND STYLISH DESIGN** - Equipped with Christophe leather straps, signature product of Zéfal.



## URBAN BACKPACK

Ref. 7057

### // URBAN BIKE BACKPACK



**ECOLOGICAL AND SUSTAINABLE MATERIAL** - RPET, recycled from plastic bottles.

**CONVERTIBLE INTO A BICYCLE RACK BAG** - Universal attachment for transport on rear rack.

**PRACTICAL** - Several external storage compartments, double access to main pocket, straps for a U-shaped lock.

**WATERPROOF** - Roll-up closure, waterproof zips and rain cover included with practical storage of it.

**MINIMALIST AND STYLISH DESIGN** - Equipped with Christophe leather straps, signature product of Zéfal.



#### URBAN MESSENGER BAG

- > **MATERIAL** RPET
- > **MOUNTING** rack mount up to Ø20mm tube + shoulder strap
- > **CAPACITY** 11 L
- > **CLOSING** Water repellent zip + magnet
- > **DIMENSIONS** 350 x 300 x 130 mm
- > **WEIGHT** 840 g

#### URBAN BACKPACK

- > **MATERIAL** RPET
- > **MOUNTING** rack mount up to Ø20mm tube + shoulder strap
- > **CAPACITY** 27 L
- > **CLOSING** Water repellent zip + leather strap
- > **DIMENSIONS** 300 x 450 x 130 mm
- > **WEIGHT** 1,18 kg

## Z TRAVELER 40

Ref. 7039C

### // REAR BAG

- +** **UNIVERSAL MOUNTING** - For all types of pannier racks.
- TOOLS FREE** - No tools required for assembling.
- RESISTANT MATERIAL** - Made from a highly resistant fabric.
- WATER RESISTANT** - Rain cover.
- REFLECTIVE STRIPES** - Better visibility of the bike.



## Z TRAVELER 60

Ref. 7039A

### // REAR BAG

- +** **LARGE VOLUME** - Bag with one main extendable pocket.
- LIGHT MOUNT** - Increase the security at night.



## Z TRAVELER 80

Ref. 7039B

### // REAR BAG WITH MODULAR VOLUME

- +** **REINFORCED SIDE POCKETS** - The foldout side pockets are made from EVA shells.



#### Z TRAVELER 40

- > **MATERIAL** Polyurethane 600D
- > **MOUNTING** Universal using Velcro®
- > **CAPACITY** 9 L
- > **CLOSING** Water repellent zip
- > **DIMENSIONS** 310 x 160 x 180 mm
- > **WEIGHT** 450 g

#### Z TRAVELER 60

- > **MATERIAL** Polyester 840D
- > **MOUNTING** Self gripping straps
- > **CAPACITY** 20 L
- > **CLOSING** Clip-on buckles
- > **DIMENSIONS** 320 x 180 x 220 mm
- > **WEIGHT** 710 g

#### Z TRAVELER 80

- > **MATERIAL** Polyester 840D
- > **MOUNTING** Universal using Velcro®
- > **CAPACITY** 8L - 32 L
- > **CLOSING** Water repellent zip
- > **DIMENSIONS** 320 x 230 x 215 mm
- > **WEIGHT** 1 kg

## RAIDER FRONT

Ref. 7510

### // FRONT RACK



**ALL IN ALUMINIUM** - Durability, lightweight and high resistance to corrosion.

**ADJUSTABLE** - Can suit different types of bikes.



## RAIDER 30

Ref. 7570

### // LUGGAGE RACK FOR SEATPOST



**ALL IN ALUMINIUM** - Durability, lightweight and high resistance to corrosion.

**ADJUSTABLE** - Can suit different types of bikes.

**TOOLS FREE** - Easy and quick installation.

**SIDE STRUCTURES** - Good holding of bags.



#### RAIDER FRONT

- > **MATERIAL**  
High resistant hollow aluminium 6061 structure
- > **SELF SIZE**  
300 x 295 mm
- > **WHEEL DIAMETER**  
26", 27.5", 28", 29"
- > **MOUNTING**  
On fork from Ø 25 to 42 mm
- > **MAXIMUM LOAD**  
Max. 2 x 9kg  
(complying with ISO 11243:2016 standard)
- > **DIMENSIONS**  
172 x 391 x 400 mm
- > **WEIGHT**  
750 g

#### RAIDER R30

- > **MATERIAL**  
High resistant hollow aluminium 6061 structure
- > **PLATFORM DIMENSIONS**  
120 x 335 mm
- > **WHEEL DIAMETER**  
26" - 27.5" - 28" - 29"
- > **MOUNTING**  
On the seat post from Ø 25.4 to 31.8 mm
- > **MAXIMUM LOAD**  
Max. 10 kg (complying with ISO 11243:2016 standard)
- > **DIMENSIONS**  
140 x 550 x 153 mm
- > **WEIGHT**  
910 g

**RAIDER R50**

Ref. 7541

**// REAR RACK**

**ALL IN ALUMINIUM** - Durability, lightweight and high resistance to corrosion.

**ADJUSTABLE** - Suitable for all types of bikes except some models with disc brakes.

**CHILD SEAT COMPATIBLE** - The RAIDER R50 is compatible with an approved child seat, up to a maximum total load of 27kg.

**HOOKS** - For tensioners.

**RAIDER R70**

Ref. 7542

**// UNIVERSAL REAR RACK**

**COMPATIBLE WITH DISC BRAKES** - Adaptable product - can be used with disc brakes.

**ALL IN ALUMINIUM** - Durability, lightweight and high resistance to corrosion.

**CHILD SEAT COMPATIBLE** - The RAIDER R70 is compatible with an approved child seat, up to a maximum total load of 27kg.

**HOOKS** - For tensioners.

**SIDE STRUCTURES** - Good holding of bags.



## RAIDER R50

- > **MATERIAL** High resistant hollow aluminium 6061 structure
- > **PLATFORM DIMENSIONS** 120 x 350 mm
- > **WHEEL DIAMETER** 26", 27.5", 28", 29"
- > **MOUNTING** Threaded studs
- > **MAXIMUM LOAD** Max.27 kg (complying with ISO 11243:2016 standard)
- > **DIMENSIONS** 164 x 400 x 400 mm
- > **WEIGHT** 765 g

## RAIDER R70

- > **MATERIAL** High resistant hollow aluminium 6061 structure
- > **PLATFORM DIMENSIONS** 120 x 350 mm
- > **WHEEL DIAMETER** 26", 27.5", 28", 29"
- > **MOUNTING** Threaded studs
- > **MAXIMUM LOAD** Max.27 kg (complying with ISO 11243:2016 standard)
- > **DIMENSIONS** 185 x 400 x 400 mm
- > **WEIGHT** 1,1 kg



## Z CONSOLE DRY Ref. 7052A - 7052B

### // WATERPROOF SMARTPHONE HOLDER

- +** **WATERTIGHT** - Protects the smartphone from rain, mud and any other impacts.
- UNIVERSAL** - Compatible with all smartphones.
- TOUCH SCREEN WINDOW** - Still use your smartphone through the protective case.
- CAMERA WINDOW** - Possible to take videos and photos through the transparent window.
- DUAL ORIENTATION OF THE SMARTPHONE** - Adjustable angle in landscape or portrait mode.



## UNIVERSAL PHONE HOLDER Ref. 7279

**NEW**

### // UNIVERSAL BIKE SMARTPHONE HOLDER

The Universal Phone Holder is a universal smartphone holder. It's ideal for commuters and touring cyclists who want to keep their device safely within reach while riding. The holder is easily attached to the handlebars or stem using a sturdy, adjustable silicone strap. It can also be left permanently on the bike. The adjustable clamp allows quick installation and a firm hold for your smartphone, whatever its size. Once installed, your phone is securely fastened and you can use it with one hand in portrait or landscape mode.



- +** **UNIVERSAL** - Holder compatible with all smartphones and all standard handlebars.
- USE** - The smartphone is easily attached and removed.
- ROBUST** - Soft contacts and silicone fastening absorb vibrations and protect the smartphone.
- ACCESSIBLE** - Lock and unlock your phone with one hand in a second.
- ROTATING SUPPORT** - Easy to switch between landscape and portrait mode.



#### Z CONSOLE DRY

- > **MATERIAL** TPU 420D
- > **MAXIMAL SIZE OF THE SMARTPHONE**  
M : 150 x 72 x 10 mm  
L : 170 x 84 x 10 mm
- > **SIZE OF THE WINDOW**  
130 x 62 mm / 150 x 68 mm
- > **MOUNTING** Z Bike Mount (with 4 o-rings  
(Ø 2 x 33 mm et Ø 2 x 36 mm))
- > **WATERPROOF**
- > **DIMENSIONS** 172 x 391 x 400 mm
- > **WEIGHT** 47 g / 54 g

#### UNIVERSAL PHONE HOLDER

- > **MATERIAL** Thermoplastic + silicone
- > **PHONE COMPATIBILITY**  
Width 60 mm to 100 mm
- > **MOUNTING** With silicone strap on Ø 22 to 38 mm
- > **DIMENSIONS** 75 x 40 x 65 mm
- > **WEIGHT** 75 g

# BIKE TAXI

Ref. 7035

## // BIKE TOW ROPE

This bike tow rope has been designed to make family cycling, especially mountain biking, more fun and enjoyable for everyone. The Bike Taxi is only to be used on paths, where it is easy to take your child up climbs and thus eliminate physical differences.

The Bike Taxi is simply installed on the saddle rails of the person towing and is very quick to attach to the stem of the towed bike. Once at the top, the child can easily unhook it. The rope is made of high density polyethylene fibre, which is highly resistant to abrasion, and is self-retracting, without risk.

The Bike Taxi is suitable for all types of bicycles and the person towing can use an E-bike



- +** **UNIVERSAL** - For all standard saddle rails.
- EASY TO INSTALL** - No tools required.
- EASY TO HANDLE** - Fast attachment and detachment.
- SAFE** - High-performance reel with complete return of the wire.
- LIGHTWEIGHT AND COMPACT** - Discreet, under the saddle, for only 140 g.

# BIKE TAXI ADAPTER

Ref. 7038

## // QUILL STEM ADAPTER FOR BIKE TAXI TOW ROPE

The Bike Taxi Adapter is an accessory specially designed to enable the Bike Taxi tow rope to be used on a bike fitted with a quill stem or any other type of smooth stem with no exposed bolts.

It can be fitted quickly and easily to the handlebars of the bike to be towed, without the need for tools. Once in place, the Bike Taxi loop attaches to the adapter, allowing the rider of the towed bike to break the connection at any time. The adapter remains in place on the handlebars, while the buckle retracts automatically and safely.

- +** **UNIVERSAL** - Handlebars from 22.2 mm to 25.4 mm.
- EASY TO INSTALL** - No tools required.
- EASY TO HANDLE** - Fast attachment and detachment.
- SAFE** - The towing cable remains free.
- LIGHTWEIGHT AND COMPACT** - Discreet, under the saddle, for only 50 g.



**NEW**



### BIKE TAXI

- > **MATERIAL** Polyamide.  
Rope: high density polyethylene
- > **DIMENSIONS (L x l x h)**  
85 x 70 x 47 mm
- > **ROPE LENGTH** 2 m
- > **WEIGHT** 140 g
- > **MAXIMUM LOAD** 95 kg

### BIKE TAXI ADAPTER

- > **MATERIAL** Polymer
- > **DIMENSIONS** 92 x 61 x 49 mm
- > **WEIGHT** 50 g
- > **MAXIMUM LOAD** 95 kg





**// INFLATION**

# ZÉFAL MT. MINI

Ref. 8470

## // MTB MINI-PUMP

The Zéfal Mt. Mini is a mini pump ideal for inflating all types of mountain bike tyres (from 2.0» to 3.0» wide and regardless of the wheel diameter, 29», 27.5» or even 26»). Mountain bike tyres require a large volume of inflation at low pressures. With an optimized inflation chamber and a direct hose connection, the Zéfal Mt. Mini has all the advantages for quickly reinflating your mountain bike after a puncture.



**ALL ALUMINIUM** - Robust and light.

**DIRECT CONNECTION WITH LEVER** - Guaranteed airtightness for easy inflation.

**FLEXIBLE CONNECTION** - Allows inflation from farther away to prevent damage to the valve stem.

**LOCK MAGNET** - Magnetic closure, quicker and easier.

**MOUNTING CLIP** - Bike mounting clip included.



> **TIRE WIDTH**

2.0" - 3.0"

> **CONNECTION**

Reversible Presta / Schrader

> **WEIGHT**

208 g

> **MOUNTING**

Clip universel (ref. 1095)

> **DIMENSIONS**

230 mm x 35 mm x 44 mm

> **MATERIAL**

Aluminium

> **MAXIMUM PRESSURE**

4 Bar / 58 psi



# ZÉFAL ROAD MINI & MICRO

## // MINI-PUMP FOR ROAD BIKE

- +** **ALL ALUMINIUM** - Robust and light.
- DIRECT CONNECTION WITH LEVER** - Guaranteed airtightness for easy inflation.
- LOCKING HANDLE** - Flexible ring.
- MOUNTING CLIP** - Bike mounting clip included.

### + MICRO

**COMPACT AND LIGHTWEIGHT** - Most compact mini pump in the range.



Ref. 8480



Ref. 8490



### MINI

- > **TIRE WIDTH**  
23 - 32 mm
- > **CONNECTION**  
Reversible Presta / Schrader
- > **WEIGHT**  
117 g
- > **MOUNTING**  
Clip (1110B)
- > **DIMENSIONS**  
230mm x 25mm x 32 mm
- > **MATERIAL**  
Aluminium
- > **MAXIMUM PRESSURE**  
8 Bar / 116 psi

### MICRO

- > **TIRE WIDTH**  
23 - 32 mm
- > **CONNECTION**  
Reversible Presta / Schrader
- > **WEIGHT**  
95 g
- > **MOUNTING**  
Clip (ref. 1095)
- > **DIMENSIONS**  
165 mm x 25 mm x 32 mm
- > **MATERIAL**  
Aluminium
- > **MAXIMUM PRESSURE**  
7 Bar / 100 psi

## ZÉFAL GRAVEL MINI

Ref. 8500

### // MINI-PUMP FOR GRAVEL BIKES



**ALL ALUMINIUM** - Robust and light.

**LOCK MAGNET** - Magnetic closure, quicker and easier.

**MUD PROTECTION** - Prevents dirt and stays clean.

**FLEXIBLE CONNECTION** - Allows inflation from farther away to prevent damage to the valve stem.

**MOUNTING CLIP** - Bike mounting clip included.



## ZÉFAL SWITCH MINI

Ref. 8460

### // VERSATILE MINI-PUMP



**Z-SWITCH SYSTEM** - Easy change from Presta to Schrader or Dunlop via a simple switch.

**ALUMINIUM** - Robust and light.

**DIRECT CONNECTION WITH LEVER** - Guaranteed airtightness for easy inflation.

**LOCKING HANDLE** - Flexible ring.

**MOUNTING CLIP** - Bike mounting clip included.



#### GRAVEL MINI

- > **TIRE WIDTH**  
35 - 47 mm
- > **CONNECTION**  
Z-Turn (Presta - Schrader)
- > **WEIGHT**  
105 g
- > **MOUNTING**  
Clip universel (ref. 8443)
- > **DIMENSIONS**  
180 mm x 34.5 mm x 24.5 mm
- > **MATERIAL**  
Aluminium
- > **MAXIMUM PRESSURE**  
5.5 bar / 80 psi

#### SWITCH MINI

- > **TIRE WIDTH**  
35 - 47 mm
- > **CONNECTION**  
Z-Switch (Presta - Schrader - Dunlop)
- > **WEIGHT**  
110 g
- > **MOUNTING**  
Clip (1110B)
- > **DIMENSIONS**  
200 mm x 33 mm x 28.5 mm
- > **MATERIAL HANDLE / BARREL**  
Thermoplastic / Aluminium
- > **MAXIMUM PRESSURE**  
5.5 bar / 80 psi

## EZ MAX FC

Ref. 4080

### // CO2 INFLATOR AND MINI-PUMP

- +** **Z-TURN SYSTEM** - Reversible, screwable connection, intuitive and compact. Allows for remote inflation ensuring valve safety.
- UNIVERSEL** - Compatible with Schrader and Presta valves.
- LOCK MAGNET** - Magnetic closure, quicker and easier.
- PROTECTIVE COATING** - Protection against cold made by the cartridge and for a better comfort.
- 2 IN 1** - CO2 inflator and mini-pump. Easy and quick inflation.



## EZ BIG SHOT

Ref. 4051

Ref. 4052

### // CONTROL DRIVE CO2 INFLATOR

- +** **Z-PUSH SYSTEM** - For an accurate and easy flow regulation. The cartridge will be empty only when the pump comes into contact with the valve.
- UNIVERSAL** - Compatible with Schrader, Presta and Dunlop valves.
- LIGHT** - Only 20g.
- PROTECTIVE COATING** - Protection against the cold made by the cartridge and for a better comfort.



## CO2 HOLDER

Ref. 1071

### // HOLDER FOR CO2 INFLATOR AND CARTRIDGE



EZ MAX FC

EZ BIG SHOT

- > **CONNECTION** Z-Turn
- > **WEIGHT (WITHOUT CARTRIDGE)** 124 g
- > **DIMENSIONS** 190 x 15 x 15 mm
- > **COMPATIBLE CARTRIDGE TYPE** 12 g, 16 g and 25 g threaded
- > **CARTRIDGE INCLUDED** 16g threaded cartridge
- > **MOUNTING** Flexible fastening clip
- > **PRESSION MAX** 8 bar / 116 psi

- > **CONNECTION** Z-Push
- > **WEIGHT (WITHOUT CARTRIDGE)** 20 g
- > **MATERIAL** Aluminium
- > **DIMENSIONS** 40 x 30 x 16 mm
- > **COMPATIBLE CARTRIDGE TYPE** 12 g, 16 g and 25 g threaded
- > **CARTRIDGE INCLUDED** 16g threaded cartridge
- > **AIR REGULATION**
- > **MOUNTING** Not included



## EZ CONTROL FC

Ref. 4040

// CO2 PUMPS WITH FLEXIBLE CONNECTION



## EZ CONTROL

Ref. 4015

// CO2 INFLATOR WITH AIR CONTROL SYSTEM



## EZ ADAPTOR

Ref. 4005

// UNIVERSAL CO2 INFLATOR



## CO2

// CO2 CARTRIDGE

	16 G	25 G
CONNECTION	Threaded	Threaded
DISPLAY (QUANTITY)	4160C(x20)	4250C(x20)
BOX (QUANTITY)	4160B(x2)	4250D(x2)



### EZ CONTROL FC

- > **CONNECTION** Z-Flow
- > **WEIGHT (WITHOUT CARTRIDGE)** 32 g
- > **MATERIAL** Aluminium with reinforced rubber hose.
- > **DIMENSIONS** 120 x 15 x 15 mm
- > **COMPATIBLE CARTRIDGE TYPE** 12 g, 16 g and 25 g threaded
- > **CARTRIDGE INCLUDED** 16g threaded cartridge
- > **MOUNTING** Not included

### EZ CONTROL

- > **CONNECTION** Z-Flow
- > **WEIGHT (WITHOUT CARTRIDGE)** 20 g
- > **MATERIAL** Aluminium
- > **DIMENSIONS** 46 x 15 x 15 mm
- > **COMPATIBLE CARTRIDGE TYPE** 12 g, 16 g and 25 g threaded
- > **CARTRIDGE INCLUDED** 16g threaded cartridge
- > **AIR REGULATION**
- > **MOUNTING** Not included

### EZ ADAPTOR

- > **CONNECTION** Direct
- > **WEIGHT (WITHOUT CARTRIDGE)** 10 g
- > **MATERIAL** Aluminium
- > **DIMENSIONS** 37 x 15 x 15 mm
- > **COMPATIBLE CARTRIDGE TYPE** 12 g, 16 g and 25 g threaded
- > **CARTRIDGE INCLUDED** 16g threaded cartridge
- > **MOUNTING** Not included

## Z SHOCK

Ref. 0661

### // MTB SHOCK PUMP

- +** **PERFORMANCE AND PRECISION** - The two-step connection guarantees precise inflation without the risk of air leaks.
- ALL ALUMINIUM** - Durable, lightweight and resistant to corrosion.
- INTEGRATED PRESSURE GAUGE AND PRESSURE REGULATOR** - Accurate inflation, easy to read and to adjust.
- COMFORT** - Ergonomic handles for a good grip.
- UNIVERSAL** - System compatible with all types of shock absorbers.



## TUBELESS TANK

Ref. 4300

### // TUBELESS AIR TANK

- +** **BOOST AIR SYSTEM** - Instant inflation and rapid fit of tubeless tyre onto rim.
- VALVE TOOL SUPPLIED** - For removing Presta valves.
- DIRECT CONNECTION** - Direct connection without any loss of flow.
- AUTONOMOUS** - Does not require electricity. Environmentally friendly and silent.
- EASY TO CARRY** - Ergonomic handle.



#### Z SHOCK

- > **WEIGHT**  
235 g
- > **MOUNTING**  
No
- > **DIMENSIONS**  
295 x 95 x 55 mm
- > **MATERIAL**  
Aluminium
- > **MAXIMUM PRESSURE**  
25 bar / 360 psi
- > **MUD PROTECTION**  
No
- > **GAUGE DIAMETER**  
Ø 40 mm

#### TUBELESS TANK

- > **CONNECTION** Direct Presta
- > **WEIGHT** 1,6 kg
- > **MATERIAL** Thermoplastic ABS
- > **FINISH** Polished
- > **HOSE LENGTH** 1000 mm / 39"
- > **RECOMMENDED PRESSURE**  
10 bar / 145 psi
- > **MAX. RECOMMENDED PRESSURE**  
16 bar / 230 psi
- > **TANK** Aluminium
- > **TANK CAPACITY** 1 L



## PROFIL MAX FP65

Ref. 0868 / 1868

### // FLOOR PUMP WITH A DIGITAL GAUGE

- +** **HANDLE MADE FROM WOOD SOURCED IN FRANCE** - Wood sourced from sustainable forests. Robust and high-quality.
- DIGITAL PRESSURE GAUGE** - Accurate (+/-1%) and legible pressure measurement (0.1 Bar / 1 PSI). Low battery indicator.
- LARGE REINFORCED BASE** - Reinforced material providing a high level of rigidity.
- INTEGRATED LOCKING HOOK** - For handle and hose.
- > **Z-SWITCH SYSTEM** - Easy change from Presta to Schrader or Dunlop via a simple switch.
- > **Z-TURN** - Screw-on intuitive connection, compatible with Presta and Schrader valves.



## PROFIL MAX FP60

Ref. 0866 / 1866

### // UNIVERSAL FLOOR PUMP

- +** **HANDLE MADE FROM WOOD SOURCED IN FRANCE** - Wood sourced from sustainable forests. Robust and high-quality.
- GAUGE WITH MAGNIFYING LENS** - Easier gauge reading.
- LARGE REINFORCED BASE** - Reinforced material providing a high level of rigidity.
- INTEGRATED LOCKING HOOK** - For handle and hose.
- > **Z-SWITCH SYSTEM** - Easy change from Presta to Schrader or Dunlop via a simple switch.
- > **Z-TURN** - Screw-on intuitive connection, compatible with Presta and Schrader valves.



FP65 & FP60

- > **CONNECTION** Z-Switch / Z-Turn
- > **WEIGHT** 1,1 kg
- > **DIMENSIONS**  
678 mm x 272 mm x 162 mm
- > **HANDLE MATERIAL**  
Natural beech wood
- > **BARREL MATERIAL**  
Anodised aluminium
- > **BASE MATERIAL**  
Reinforced composite
- > **HOSE LENGTH** 1100 mm
- > **GAUGE DIAMETER** Ø 70 mm
- > **MAXIMUM PRESSURE** 12 bar



Z-SWITCH

- > **FP60** : Ref. 1866
- > **FP65** : Ref. 1868



Z-SWITCH

- > **FP60** : Ref. 0866
- > **FP65** : Ref. 0868

## PROFIL MAX FP30

Ref. 0864

### // UNIVERSAL FLOOR PUMP



**Z-SWITCH SYSTEM** - Easy change from Presta to Schrader or Dunlop via a simple switch.

**LONG HOSE** - Access to the valve easier.

**GAUGE WITH MAGNIFYING LENS** - Easier gauge reading.

**INTEGRATED LOCKING HOOK** - For handle and hose.

**ADDED FEATURES** - Ball and bladder heads.



## PROFIL MAX FP20

Ref. 0862

### // FLOOR PUMP WITH A WIDE GAUGE & A Z-SWITCH INTUITIVE CONNECTION



**Z-SWITCH SYSTEM** - Easy change from Presta to Schrader or Dunlop via a simple switch.

**WIDE GAUGE** - Precise inflation via highly visible gauge.

**STEEL BASE** - Better stability.

**ADDED FEATURES** - Ball and bladder heads.



FP30

- > **CONNECTION** Z-Switch
- > **WEIGHT** 1,3 kg
- > **DIMENSIONS**  
650 mm x 270 mm x 160 mm
- > **HANDLE MATERIAL**  
Technopolymer
- > **BARREL MATERIAL**  
Steel
- > **BASE MATERIAL**  
Composite
- > **HOSE LENGTH** 1100 mm
- > **GAUGE DIAMETER** Ø 63 mm
- > **MAXIMUM PRESSURE** 11 bar

FP20

- > **CONNECTION** Z-Switch
- > **WEIGHT** 1,2 kg
- > **DIMENSIONS**  
650 mm x 270 mm x 160 mm
- > **HANDLE MATERIAL**  
Technopolymer
- > **BARREL MATERIAL**  
Steel
- > **BASE MATERIAL**  
Steel + pads
- > **HOSE LENGTH** 800 mm
- > **GAUGE DIAMETER** Ø 72 mm
- > **MAXIMUM PRESSURE** 9 bar



**// MAINTAIN**

# BIKE SHAMPOO

Ref. 9974

## // CONCENTRATED BIKE CLEANER WITH ECOCERT ECODETERGENT LABEL



**30 WASHES** - On average, 1L of product is sufficient for 10 washes.

**ECOCERT** - Certification guarantees and promotes best social and environmental practice.

**VERSATILE** - Can be used safely on all surfaces of your bike.

**SPRAYER** - Its dual position allows it to produce an active washing foam or to spray the parts to be cleaned.

**REUSABLE BOTTLE** - Made from recycled plastic, it can be reused with Bike Shampoo Refill.



### > CAPACITY

3 L

### > CONTAINER

Bottle 1 L

### > FEATURES

Content: less than 5%: non-ionic surfactants, amphoteric surfactants. Also contains: water, sequestrant, carbonate salts. 99% of all ingredients are of natural origin.

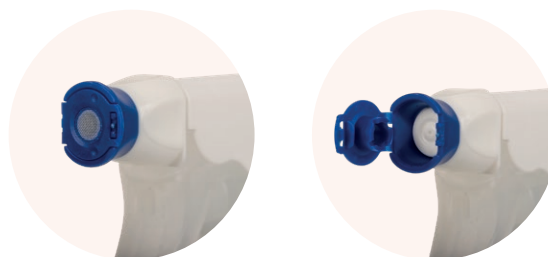

## BIKE SHAMPOO REFILL

Ref. 9975

## // REFILL OF CONCENTRATE BIKE CLEANER WITH ECOCERT ECODETERGENT LABEL



### > CAPACITY

1 L

### > CONTAINER

300 ml



# BIKE DEGREASER

Ref. 9982

## // BIKE DEGREASER

- +** **DOUBLE ACTION** - Detergent and degreasing action.
- SAFE FOR THE ENVIRONMENT** - 100% biodegradable according to OECD 302B test conditions.
- QUICK CLEANING** - Removes stains quickly and effectively.
- BIG CAPACITY** - 1 Litre capacity giving greater number of uses.
- SPRAY** - Allows quick and accurate spraying of the parts to be cleaned.



# DISC BRAKE CLEANER

Ref. 9986

## // DISC BRAKE CLEANER

- +** **BETTER BRAKING WITHOUT THE NOISE** - Re-establishes original performance.
- LIFE SPAN** - Prolongs the lifespan of the brakes.
- QUICK DRYING** - Fast cleaning without any residue.
- ACETONE AND CMR-FREE** - Guaranteed no risk to plastic or painted parts.



### BIKE DEGREASER

- > **CAPACITY**  
1 L
- > **CONTAINER**  
Bottle
- > **FEATURES**  
10% or more: Water  
1% < 10% : Non-ionic surfactants  
1% < 10% : Calcium salts  
0,1% < 1% : Sodium carbonate  
0,1% < 1% : Amphoteric surfactants  
0,1% < 1% : Perfumes
- > **DIMENSIONS**  
310 mm x 100 mm x 76 mm

### DISC BRAKE CLEANER

- > **CAPACITY**  
400 ml
- > **CONTAINER**  
Aerosol
- > **FEATURES**  
Acetone and CMR-Free. Contains Hydrocarbons, C8-C9, isoalkanes.
- > **DIMENSIONS**  
252 mm x 57 mm x 57 mm



## ZB CLEAN

Ref. 1193

### // 3 IN 1 BRUSH FOR TRANSMISSION

- +** **DUAL MATERIAL HANDLE** - Ergonomic and non-slippery.
- LARGE BRUSH** - Ideal for cleaning the chain and freewheel.
- SMALL BRUSH** - Perfect for derailleur and bearing.
- SCRAPER** - Scraper for an accurate cleaning of the free-wheel (compatible 8-9-10-11-12 gears).



## ZB TWIST

Ref. 1194

### // DOUBLE-HEADED BRUSH

- +** **DUAL MATERIAL HANDLE** - Ergonomic and non-slippery.
- ADJUSTABLE DOUBLE HEAD** - Suitable positions for cleaning.



## ZB WASH

Ref. 1191

### // BRUSH FOR CLEANING THE BIKE

- +** **DUAL MATERIAL HANDLE** - Ergonomic and non-slippery.
- SOFT PARTS** - Do not scratch the frame.



#### ZB CLEAN

- > **BRUSH MATERIAL**  
Nylon
- > **HANDLE MATERIAL**  
Polypropylene
- > **DIMENSIONS**  
210 mm / 8,3"
- > **WEIGHT**  
90 g

#### ZB TWIST

- > **BRUSH MATERIAL**  
Nylon
- > **HANDLE MATERIAL**  
Polypropylene
- > **DIMENSIONS**  
260 mm / 10.2"
- > **WEIGHT**  
109 g

#### ZB WASH

- > **BRUSH MATERIAL**  
Nylon
- > **HANDLE MATERIAL**  
Polypropylene
- > **DIMENSIONS**  
280 mm / 11"
- > **WORK SURFACE**  
150 x 100 mm / 5.9 x 3.9"
- > **WEIGHT**  
218 g

## EXTRA WET LUBE

### // PREMIUM, CERAMIC-BASED LUBRICANT FOR THE CHAIN

- +** **ALL CONDITIONS** - Effective no matter what the conditions are.
- EXCEPTIONAL DURABILITY** - Effective over very long distances.
- FRICTION REDUCTION** - Smoother pedalling and a quieter drivetrain.
- HIGHLY WATER RESISTANT** - Anti-corrosive properties, prolonging the life of the componentry.
- EASY APPLICATION** - Drip-regulation safety cap.



## EXTRA DRY WAX

### // PREMIUM WAX-BASED LUBRICANT

- +** **IDEAL IN DRY WEATHER** - Outstanding durability.
- CLEAN CHAIN** - Clean lubrication with this wax.
- FRICTION REDUCTION** - Smoother pedalling and a quieter drivetrain.
- NON-OILY PROTECTIVE FILM** - Efficiently repels dust and dirt.
- EASY APPLICATION** - Drip-regulation safety cap.



## EBIKE CHAIN LUBE

### // ALL CONDITIONS LUBRICANT FOR EBIKE

- +** **SPECIAL EBIKE** - Formulated with extreme pressure additives optimised to withstand high engine torque.
- EXCEPTIONAL DURABILITY** - Effective over very long distances.
- ALL CONDITIONS** - Effective no matter what the conditions are.
- HIGH DEGREE OF ADHESION** - Penetrating. Spreads easily over all surfaces.
- EASY APPLICATION** - Drip-regulation safety cap.



## PRO WET LUBE

### // BIODEGRADABLE LUBRICANT FOR THE CHAIN

- +** **ALL CONDITIONS** - Effective no matter what the conditions are.
- FRICTION REDUCTION** - Smoother pedalling and a quieter drivetrain.
- HIGHLY WATER RESISTANT** - Anti-corrosive properties, prolonging the life of the componentry.
- EASY APPLICATION** - Drip-regulation safety cap.





	<b>PRO WET LUBE</b>	<b>EBIKE CHAIN LUBE</b>	<b>EXTRA WET LUBE</b>	<b>EXTRA DRY WAX</b>
<b>CAPACITY 120 ML</b>	9611	9616	9613	9612
<b>CAPACITY 10 ML</b>	-	9617	9615	9614
<b>CONTAINER</b>	Compressible bottle with safety cap.			
<b>WEATHER CONDITIONS</b>	All conditions			
<b>PERFORMANCE</b>	4	5	5	5
<b>DURABILITY</b>	4,5	5	5	4
<b>CLEANLINESS</b>	3,5	3,5	3,5	5



## CARBON PASTE

Ref. 9609

### // ANTI-SEIZE ASSEMBLY PASTE FOR CARBON COMPONENTS

- +** **MAKES ASSEMBLY EASIER** - The adhesive effect prevents components from being over-tightened.
- WATER RESISTANCE** - Outstanding resistance to water, salt water, mud, weathering, washing...
- ANTI-SEIZE / ANTI-COLD WELDING** - Avoids cold welding of carbon to other materials.
- PRESERVES FRICTION COMPONENTS** - Prevents cracking and therefore reduces noise.
- PLANTE BASED** - Formulated based on plant-based greases and without microplastics.



## COPPER PASTE

Ref. 9608

### // ANTI-SEIZING COPPER ASSEMBLY PASTE

- +** **HARMLESS** - Safe for plastics, carbon and rubber.



## PRO II GREASE

### // BIKE GREASE

- +** **ANTI RUST AND CORROSION** - High protection.
- WATERPROOF** - Excellent resistance to water, mud, weathering...
- STRONG ADHERENCE** - Strong adhesion power for fewer uses.



Ref. 9605



Ref. 9640



CARBON PASTE

- > **CAPACITY**  
50 ml
- > **CONTAINER**  
Tube
- > **FEATURES**  
Microbeads

COPPER PASTE

- > **CAPACITY**  
100 ml
- > **CONTAINER**  
Tube
- > **FEATURES**  
Copper base

PRO II GREASE

- > **CAPACITY**  
150 ml / 1 kg
- > **CONTAINER**  
Tube
- > **FEATURES**  
Lithium



LOT: 3012735

**ZEFAL**

ESTD

1880

**Carbon Paste**

PREMIUM QUALITY

Assembly paste for carbon components

## Z BAR TOOL

Ref. 4310

### // MULTI-TOOLS & TUBELESS REPAIR KIT STORED WITHIN THE HANDLEBARS

- +** **SLEEK FINISH** - Anodised and CNC used aluminium handlebar end plugs.
- EASY TO PULL OUT** - Multi-tools accessible with gloves.
- COMPLETE MULTI-TOOLS** - 11 screws bits
- DURABLE** - Permanently seals punctures up to 5mm for extended tyre life.
- VERSATILE** - Integrated tool for tightening the Presta valve core, with valve core supplied and option to attach a spare chain link (link not included).



## AFA 8 PLUS

Ref. 9987

### // 8-FUNCTION MULTI-TOOL INTEGRATED INTO THE BIKE

- +** **DURABLE** - Precise CNC machined steel tools with chrome finish.
- UNIVERSAL** - Support compatible with all types of frames with threaded holes for bottle cages.
- EASY ACCESS** - Multi-tools accessible with gloves.
- SECURE** - Hinged lid with hook closure.
- DISCREET** - Compact and lightweight.



#### Z BAR TOOL

- > **MATERIAL**  
Steel and anodised aluminium handlebar end plugs
- > **DIMENSIONS**  
120 x Ø 17,5 mm (excluding end plugs);  
143 x Ø 17,5 mm (excluding end plugs)
- > **WEIGHT** 67 g + 36 g
- > **HANDLEBAR COMPATIBLE**  
Ø intérieur de 17,5 mm à 21 mm
- > **TOOLS INCLUDED**  
Hex2/2.5/3/4/5/6/8; T10/25; Ø4; Ø2
- > **PLUGS**  
Oui (3 x Ø 2mm)

#### AFA 8 PLUS

- > **MATERIAL**  
Steel and aluminium tools  
Fiber reinforced polypropylene holder
- > **DIMENSIONS**  
235 x 56 x 18 mm
- > **WEIGHT** 154 g
- > **TOOLS INCLUDED**  
Hex2/2.5/3/4/5/6; T25; Ø5; Chain Tool
- > **CHAIN BREAKER**  
8 to 12 Speed
- > **SCREWS INCLUDED**  
M5 x 25 mm

## Z BAR PLUGS

Ref. 4301

### // TUBELESS REPAIR KIT STORED WITHIN THE HANDLEBARS



**SIMPLE TO USE** - No need to remove the tyre.

**DURABLE** - Permanently seals punctures up to 5mm for extended tyre life.

**EASY ACCESS** - Multi-tools accessible with gloves.

**SLEEK FINISH** - Anodised and CNC usined aluminium handlebar end plugs.

**VERSATILE** - Integrated tool for tightening the Presta valve core, with valve core supplied and option to attach a spare chain link (link not included).



## TUBELESS REPAIR TOOL

Ref. 4304

### // QUICK REPAIR TOOL FOR TUBELESS TYRES



**UNIVERSAL** - Support compatible with all types of frames with threaded holes for bottle cages.



## TUBELESS PLUGS

Ref. 4305



**PLUGS** 3 x Ø 2mm + 3 x Ø 4mm



#### Z BAR PLUGS

- > **MATERIAL** Anodised aluminium handlebar plugs
- > **DIMENSIONS**  
109 mm x Ø 17.5 mm (excluding end plugs); 143 mm x Ø 17.5 mm (excluding end plugs)
- > **WEIGHT**  
39 g + 36 g
- > **HANDLEBAR COMPATIBLE**  
Internal diameter from 17.5 mm to 21 mm
- > **PLUGS**  
3 x Ø 2 mm + 3 x Ø 4 mm

#### TUBELESS REPAIR TOOL

- > **MATERIAL** Aluminium, Steel and Polyamide
- > **DIMENSIONS**  
Ø22 mm x 110 mm
- > **WEIGHT**  
53 g
- > **MAXIMUM PRESSURE**  
6 Bar / 87 psi
- > **PLUGS**  
3 x Ø2 mm + 2 x Ø 4 mm

## TUBELESS REPAIR KIT

Ref. 4302

### // REPAIR KIT FOR TUBELESS TYRE



**SIMPLE TO USE** - No need to remove the tyre.

**DURABLE** - Permanently seals punctures up to 5mm for extended tyre life.

**STORAGE** - The box makes it easy to transport in a bag and preserves the plugs over time.

**VERSATILE** - Integrated tool for tightening the valve core and option to attach a spare chain link (link not included).



## REPAIR KIT

### // REPAIR KIT



#### TUBELESS REPAIR KIT

- > **MATERIAL** Steel and Polyamide
- > **WEIGHT** 35 g
- > **DIMENSIONS (L X W X H)** 122 mm x 35 mm x 23 mm
- > **PLUGS** 3 x Ø 2 mm + 3 x Ø 4 mm

#### REPAIR KIT

	REPAIR KIT UNIVERSAL +	REPAIR KIT MTB	REPAIR KIT ROAD	REPAIR KIT UNIVERSAL	EMERGENCY KIT
REF	1122	1131	1132B	1132A	1135C
PATCHES	Ø 25 mm x 6 / 24mm x 35 mm x 2	Ø 33 mm x 4 / 30 mm x 50 mm x 2	Ø 15 mm x 6	Ø 25 mm x 6 / 24 mm x 35 mm x 2	Ø 25 mm x 6
RUBBER CEMENT 5G	Yes				No, self-adhesive repair
GRATER	Yes				
TIRE LEVERS	Yes x 2	No			
DIMENSIONS	122 mm x 35 mm x 23 mm				



## Z LEVERS

Ref. 1990A

### // TIRE LEVER



## DP20

Ref. 2001A - 2001B

### // TIRE LEVER



## REPAIR SPRAY

### // REPAIR SPRAY FOR FLAT TYRES: REPAIRS AND REINFLATES INSTANTLY



- QUICK AND EASY** - No need to change the inner tube whilst out.
- COMPATIBLE WITH ALL TYPES OF BIKE** - All types of tyres - tubeless or standard with inner tubes.
- EASY TO CARRY** - Compact, it can be attached to the bike with a mounting system.



#### Z LEVERS

- > **MATERIAL** Resin technopolymer
- > **COLOUR** Red
- > **DIMENSIONS** 25 x 98 x 4,5 mm

#### DP20

- > **MATERIAL** Resin technopolymer
- > **COLOUR**  
2001A : Black / 2001B : Blue, white & red
- > **DIMENSIONS** 15 x 110 x 22 mm

#### REPAIR SPRAY

REF	1127	1126	1128	1129
<b>CAPACITY</b>	75 ml	100 ml	100 ml	150 ml
<b>FEATURES</b>	Foam	Foam	Foam	Foam
<b>DIMENSIONS</b>	35 x 60 x 145 mm	40 x 60 x 145 mm	40 x 60 x 145 mm	50 x 65 x 145 mm
<b>WEIGHT</b>	90 g	160 g	110 g	160 g
<b>MOUNTING SYSTEM</b>	-	-	Yes	-
<b>MAX. TIRE SIZE</b>	700 x 38	29" x 2.25"	29" x 2.25"	29" x 3.0

# Z SEALANT

Ref. 9801 - 9802 - 9821 - 9831

## // ANTI-PUNCTURE SEALANT



**CONTAINS LESS THAN 1% AMMONIA** - Won't damage your tires.

**EASYTOUSE** - Injected into the valve or directly into a tubeless tire.



# TUBELESS TAPES

## // TUBELESS RIM TAPES



**SIMPLIFIED FITTING** - Slightly elastic tapes.

**DURABILITY** - Very good pressure resistance. Minimised infiltration risk.

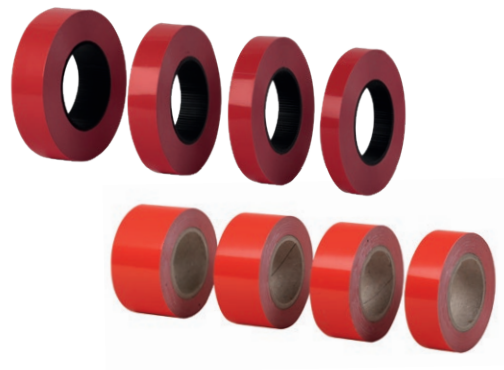

### Z SEALANT

FEATURES	CAPACITY	CONTAINER	TIRES NUMBERS (ROAD, GRAVEL, MTB)*			REF.
Less than 1% ammonia	125 ml	Flask	3	2	1	9801
	240 ml	Flask	5	4	3	9802
	1 L	Bottle	22	17	11	9821
	5 L	Jerrycan	110	83	55	9831

\*Road: 700x25, Gravel: 700x40, MTB: 29"x2,6"

### TUBELESS TAPES

MATERIAL	Elastomer adhesive		
COLOR	Red		
WIDTH	REF	TAPE	RIMS
	9395	20 mm	17-21 mm
	9400	25 mm	22-26 mm
	9396	30 mm	27-32 mm
	9401	36 mm	33-39 mm
	9397		
	9402		
	9398		
LENGTH	REF	TAPE	
	9395-9398	9 m	
	9400-9403	50 m	



# COTTON RIM TAPES

## // COTTON RIM TAPES



**RESISTANT TO HIGH PRESSURE** - The cotton material resists to pressure and high temperatures (braking).

**QUICK MOUNTING** - Easy and quick installation.



2 PIECES PACKAGING	10 PIECES DISPLAY	BULK	100 M ROLL
13 mm : 9145	13 mm : 9142	13 mm : 9144	13 mm : 9143
17 mm : 9153	17 mm : 9151	17 mm : 9150	17 mm : 9154
22 mm : 9104	22 mm : 9102	22 mm : 9105	22 mm : 9103

<b>WEIGHT</b>	13 mm	2 x 14 g
	17 mm	2 x 18 g
<b>LENGTH</b>	22 mm	2 x 22 g
2 m compatible with 29" and 700c wheels		

**Z LINER**

Ref. 9722 - 9721 - 9738 - 9723 - 9724

**// ANTI-PUNCTURE TAPE**

Fed up with flat tyres? The Z Liner is a protective tape made out of highly resistant polyurethane material and provides additional protection against the risk of getting a puncture. The Z Liner is positioned between the inner tube and the tyre to prevent getting a flat tyre. Various sizes are available depending on your tyre width. Sold in pairs. Ride along in peace thanks to the Z liner.



**MADE FROM POLYURETHANE** - Highly resistant to punctures.

**HIGH LEVEL OF QUALITY** - Particularly long product lifespan.



REF	MATERIAL	WHEEL Ø	COLORS	TAPE WEIGHT	TAPE WIDTH	TYRE WIDTH
9722	Polyurethane	All diameters	Grey	2 x 35 g	19 mm	23 mm, 25 mm, 28 mm
9721			Orange	2 x 60 g	27 mm	32 mm, 35 mm, 38 mm, 40 mm
9738			Blue	2 x 90 g	34 mm	45 mm, 47 mm, 2.0", 2.1", 2.2", 2.25"
9723			Purple	2 x 135 g	50 mm	2.4", 2.6", 2.8", 3.0"
9724			Green	2 x 215 g	75 mm	3.0", 3.5", 4.0", 4.5"

## TOE-CLIPS 43

Ref. 0430 - 0431

// TOE-CLIPS FOR FLAT PEDALS



## TOE-CLIPS 45

Ref. 0450 - 0451

// HALF TOE-CLIPS FOR FLAT PEDALS

## CHRISTOPHE STEEL TOE CLIPS

// CHROME-PLATED STEEL TOE CLIPS

Ref. 0506 - 0507



## CHRISTOPHE STEEL TOE STRAPS 515XL

Ref. 5151

// BRAIDED TOE-STRAPS



## CHRISTOPHE LEATHER TOE-STRAPS

// LEATHER TOE-STRAPS



### TOE-CLIPS 43

- > **MATERIAL**  
Technopolymer resin
- > **PRONGED TOE-CLIP**  
Double
- > **SIZES**  
S/M : Eur-42,  
US-9 #0430  
L/XL : Eur-42,  
US-9 #0431

### TOE-CLIPS 45

- > **MATERIAL**  
Technopolymer resin
- > **SIZES**  
S/M : Eur-42,  
US-9 #0451  
L/XL : Eur-42,  
US-9 #0450

### CHRISTOPHE STEEL TOE CLIPS

- > **MATERIAL**  
Chrome-plated steel
- > **PRONGED TOE-CLIP**  
Single with double rivet
- > **SIZES**  
S/M : Eur-42,  
US-9 #0506  
L/XL : Eur-42,  
US-9 #0507

### CHRISTOPHE STEEL TOE STRAPS 515XL

- > **MATERIAL**  
braided technopolymer
- > **COLOUR**  
Black
- > **LENGTH**  
440 mm

### CHRISTOPHE LEATHER TOE STRAPS

- > **MATERIAL**  
High quality leather
- > **COLOR**  
Black #5161A  
Blue #5161D  
Brown #5161F  
Red #5161E  
White #5161B
- > **LENGHT**  
370 mm



## WHY CUSTOMISE YOUR BOTTLES?

Easy to make and affordable, customized bottles can help you to promote your brand, your shop, your sports club... It could also be a great gift and souvenir for your race's attendees.

**Screen printing** is a technique whereby screens are used to transfer ink onto the bottles. This is our standard printing technique, used on all our bottles. We can print up to 4 colours and we require a minimum order of 250 identical bottles.

> [ZEFALBOTTLES.COM](http://ZEFALBOTTLES.COM)





# ZÉFAL

ZI Les Cailloux - 45150 Jargeau - France

Tel.: +33(0)2 38 59 70 45

[zefal@zefal.com](mailto:zefal@zefal.com)

ZEFAL SA with a registered capital of 1 137 774 €

Trade registry No. 572 029 106 - TVA/VAT: FR 93 572 029 106

Product specifications in this catalog are indicative and are subject to change without any notice. Pictures may differ from actual products.

June 2024 – France. © Photo credit: Ludovic Letot, Antoine Collet, Léo Denis, Kéno Derleyn, Théo Gomez, Créat'ur, Robin Nevrala, Pierre Maullet, Louis Nauche, Margaux Le Map, Olivier Béart. Creation : MAD Brain Studio.

